

ΕΠΛ 427:  
ΚΙΝΗΤΑ ΔΙΚΤΥΑ ΥΠΟΛΟΓΙΣΤΩΝ  
(MOBILE NETWORKS)

Δρ. Χριστόφορος Χριστοφόρου  
Πανεπιστήμιο Κύπρου - Τμήμα Πληροφορικής

3GPP Long Term Evolution (LTE)

# Topics Discussed

1

- LTE Motivation and Goals
- Introduction to LTE
- LTE Network Architecture
- Air Interface in LTE
- Symbols, Slots, Resource Blocks and Frames (OFDM)
- LTE Channel Structure (Downlink, Uplink)
- LTE Channel Model (Downlink, Uplink)
- MIMO Transmission & Adaptive Modulation and Coding

# LTE Motivation and Goals

2

- The main goal of LTE is to **improve Data Rates** and **QoS**.
  - ▣ The **driving force** towards the **definition of the LTE** is the **Need for Higher Data Rates**
- In addition, **Networks Operators** are looking for **Backward Compatibly, Lower Complexity** and **Cost Reduction**, support for **higher mobility (i.e., higher speeds)**, **better Spectral Efficiency** and **Improved System Latency** (lower delays and thus **increased User Experience**)
  - ▣ The **simplification of the Core Network Architecture** (adopted an **All-IP approach**), the simplification of the **Radio Network Architecture** (becoming **Flat**), and the new air interface (**OFDM**) chosen for LTE, helped to support all these goals.



# Introduction to LTE

3

- Despite constant evolution, **3G (UMTS)** is approaching a number of **inherent design limitations** in a manner similar to what GSM and GPRS did a decade ago.
- Therefore, the **3GPP** decided to once again **redesign both the Radio Network and the Core Network.**
- The result is commonly referred to as ‘**Long-Term Evolution**’ or **LTE** for short.

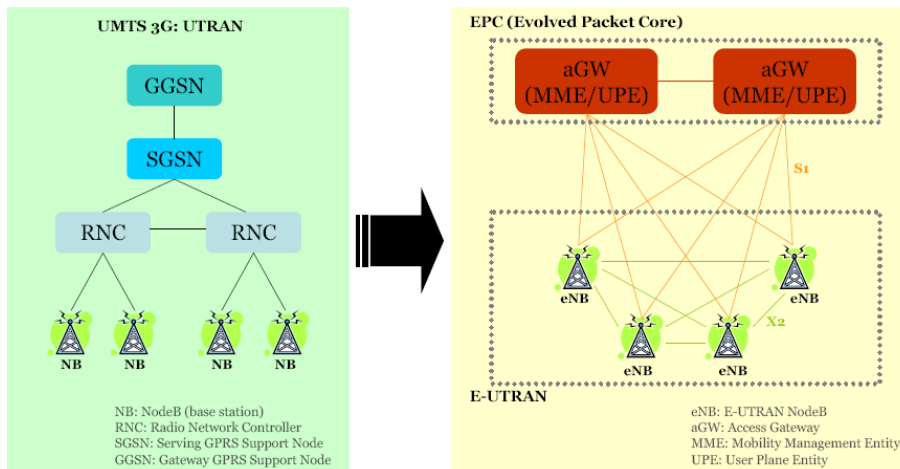

**Mobility Management Entity (MME)**

**User Plane Entity (UPE)**

# Introduction to LTE

- When UMTS was designed, it was a brave approach to **specify an air interface** with a **Carrier Bandwidth** of **5 MHz**.
- **WCDMA**, the air interface chosen at that time, **performed very well** within this **bandwidth limit**.
- Unfortunately, **WCDMA does not scale very well** (due to the fact that a **single carrier** is used to transfer the data).
  - ▣ That is because in order to **attain higher transmission speeds**, the time **between subsequent symbols has to decrease**.
  - ▣ For example assuming 1 bit is sent per symbol:
    - 64 Kbps → Subsequent Symbol time: 0.000015625 sec
    - 256 Kbps → Subsequent Symbol Time: 0.00000390625 seconds

# Introduction to LTE

5

- The **shorter** the time between **subsequent Symbols**, the **greater** the impact of **InterSymbol Interference (ISI)**, which degrades the quality of the signal considerably.

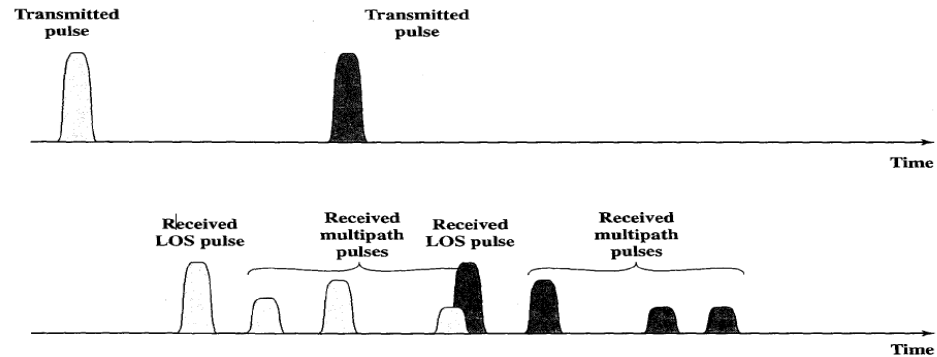

- Therefore, with LTE, a **completely different air interface (based on OFDM; Orthogonal Frequency Division Multiplexing)** has been specified to **significantly increase the data rates in the air interface** while at the same time **overcome the effects of ISI**.

# Introduction to LTE

- Instead of spreading one signal over the complete carrier bandwidth (single carrier transmission), like WCDMA does, LTE uses **Orthogonal Frequency Division Multiplexing (OFDM)** that transmits the data over **many narrowband carriers** of **180 kHz** each (**multicarrier transmission** scheme).
- Instead of a single fast transmission, a **data stream** is **split into many slower data streams** that are **transmitted simultaneously** (using many different carriers).
- As a consequence, the **achievable data rate** compared to **UMTS** is similar in the same bandwidth but the **ISI multipath effect is greatly reduced** because of the **Longer time between subsequent symbols**.

# Introduction to LTE

7

## OFDM Concept: Single-Carrier Vs. OFDM

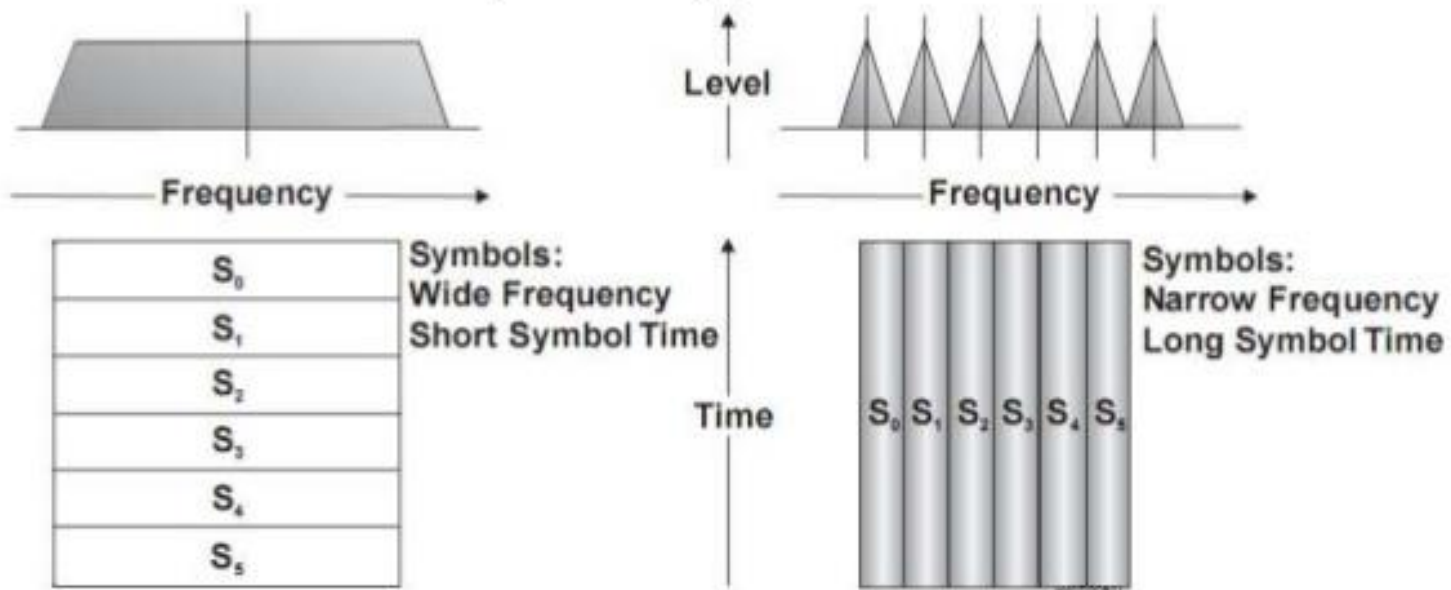

### Single-Carrier Mode:

- Serial Symbol Stream Used to Modulate a Single Wideband Carrier
- Serial Datastream Converted to Symbols (Each Symbol Can Represent 1 or More Data Bits)

### OFDM Mode:

- Each Symbol Used to Modulate a Separate Sub-Carrier



# Introduction to LTE

- **Example - Single Carrier Vs Multicarrier transmission**
  - ▣ Let assume a data stream of 256 kbps send in the same channel using the same carrier (single carrier) and that **one bit is sent per symbol**
  - ▣ This means that in one second, 256000 symbols must be transmitted in the carrier so as to achieve the 256Kbps bit rate.
  - ▣ Therefore, this gives **0.00000390625 seconds between consecutive symbols** (1 second / 256000 symbols).

# Introduction to LTE

- **Example - Single Carrier Vs Multicarrier transmission**
  - ▣ Now lets **split this data stream into eight (8) lower data rate streams** and send each stream using a different carrier (i.e., a different channel; multicarrier transmission). Also we assume that **one bit is sent per symbol.**
  - ▣ Thus, **each one of the carriers (i.e., the channels) will now transmit 32Kbps** ( $256\text{Kbps}/8$ ).
  - ▣ This means that **in one second, the number of symbols** that have to be **transmitted** is **32000** (per carrier).

# Introduction to LTE

10

- **Example - Single Carrier Vs Multicarrier transmission**
  - This **increases the time between consecutive symbols to 0.00003125 seconds** (1 second / 32000 symbols) thus **reducing significantly the effects of InterSymbol Interference (ISI)** – *Note that if the time between consecutive symbols is much greater than the delay spread then the **ISI** is mitigated.*
  - However, **all the carriers** used to send the lower data rate streams will **transmit the data simultaneously** and therefore the **achievable data rate will be the same** as with the **single carrier transmission** (i.e., 8 x 32Kbps = **256Kbps**)

# Introduction to LTE

- **Several bandwidths** have been specified for LTE:
  - **Flexible bandwidth Allocation** from **1.4 MHz** up to **20 MHz** (Note that for WCDMA the bandwidth that can be used is fixed to 5 MHz).
  - In a **20 MHz** carrier bandwidth, data rates **beyond 100 Mbit/s** can be achieved **under very good signal conditions** (using **Adaptive Modulation and Coding** and **MIMO transmissions**).

# Introduction to LTE

12

- In addition to the flexible bandwidth support, **all LTE devices have to support Multiple Input Multiple Output (MIMO) transmissions**, which allows the Base Station to transmit/receive **several data streams simultaneously**.
- Under **very good signal conditions**, the data rates that can be achieved this way are **beyond those that can be achieved with a single-stream transmission**.

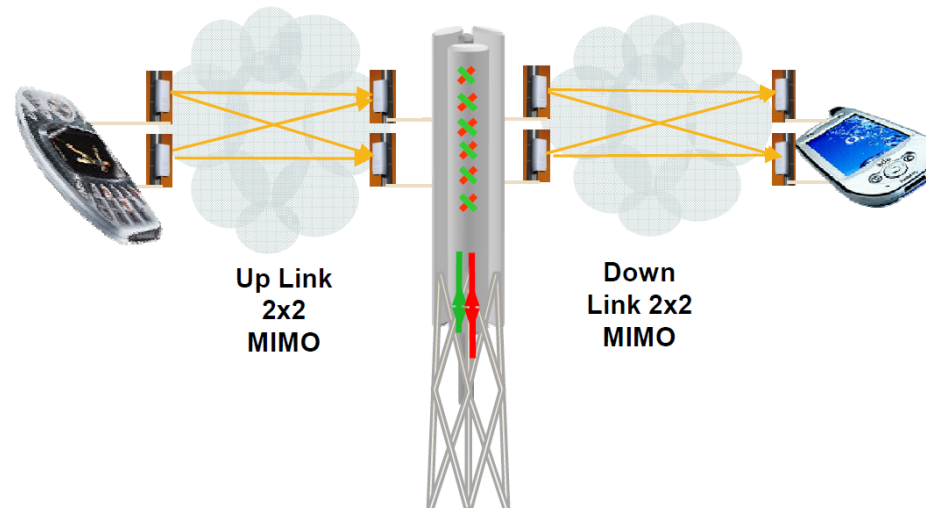

# Introduction to LTE

13

- The second major change of LTE compared to previous systems is the **adoption of an all-IP approach**.
- While UMTS used a traditional Circuit-Switched packet core for voice services, for SMS and other services inherited from GSM/GPRS/EDGE, **LTE solely relies on an IP-based Core Network (only Packet Switched services)**.

2G/3G

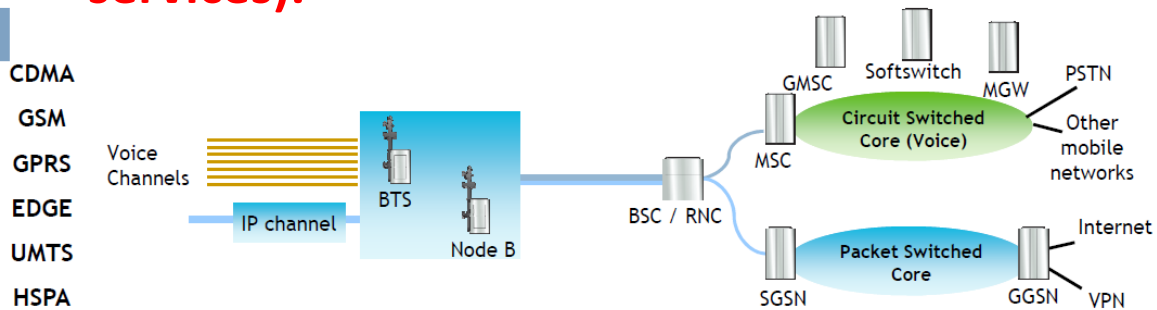

PCRF (Policy Control and Charging Rules Function)

LTE+EPC

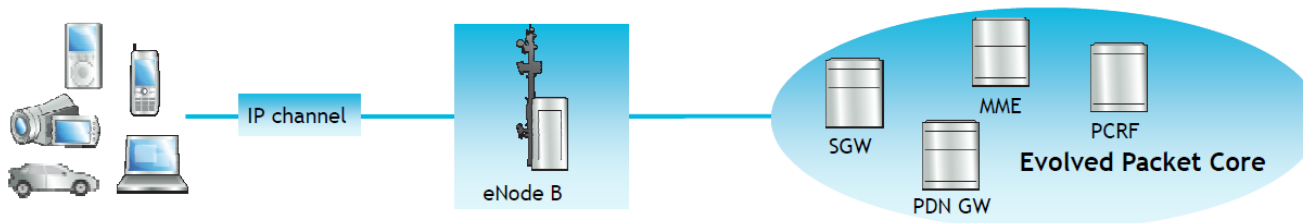

**An All IP-based Core Network Evolved Packet Core (EPC)**

# Introduction to LTE

14

- To further **simplify the network architecture** and to **reduce user data delay**, fewer logical and physical network components (e.g., **the RNC in the Radio Network of LTE is removed**) have been defined in LTE.
- In practice, this has **resulted in Round-Trip delay times of less than 25–30 milliseconds** (used to be 150 ms for UMTS).
- This **improved User Experience** since **with faster signaling, faster Mobility Management procedures** and **faster Connection Times to the network** as well as **lower Packet Delays** and **jitter** are achieved.

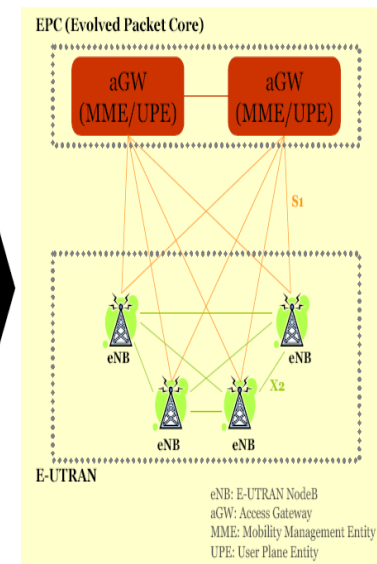
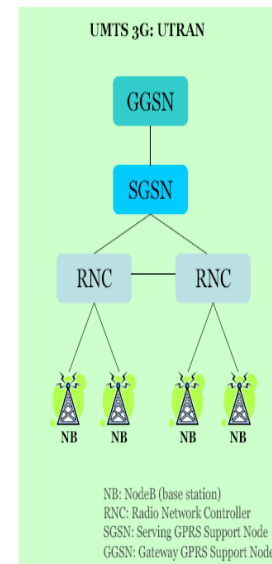

# Introduction to LTE

15

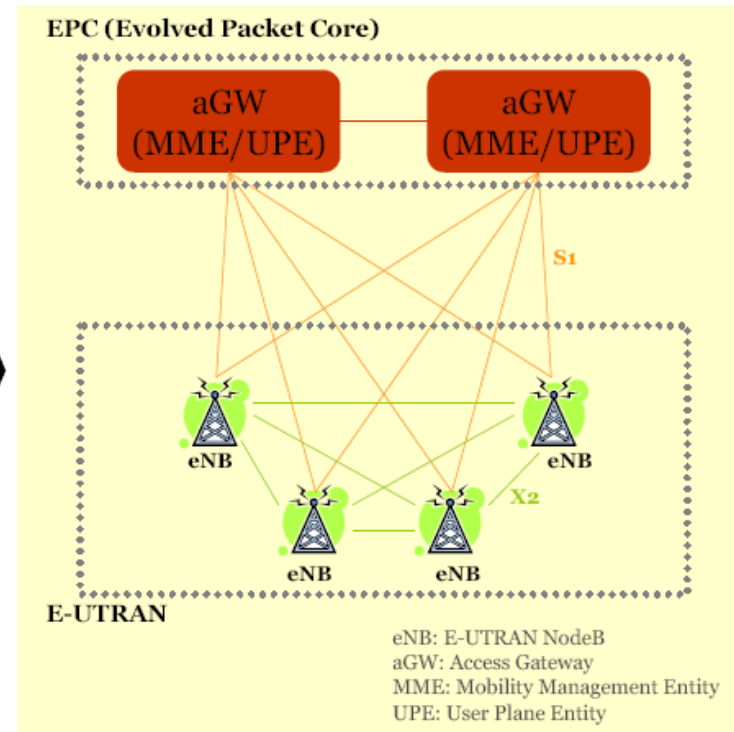
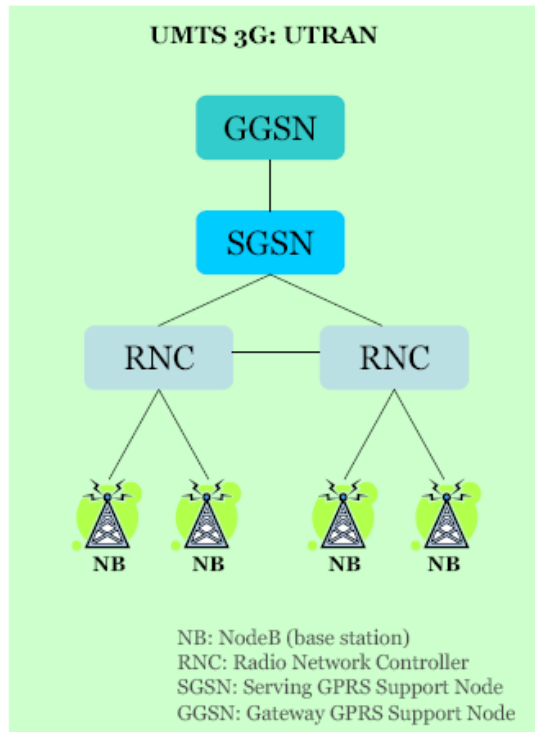

The main difference between UMTS and LTE: The **removing of RNC network element** and the **introduction of X2 interface for communication between the BSs (eNBs)**, which makes the radio network architecture **more simple and flat**, leading **lower networking cost, higher networking flexibility and lower latency**.



# Introduction to LTE

16

- Also, **all interfaces (S1, X2, S11, etc.) between network nodes in LTE are based on IP.**
- An **All-IP network architecture greatly simplifies the design and implementation of the LTE air interface, the Radio Network and the Core Network.**

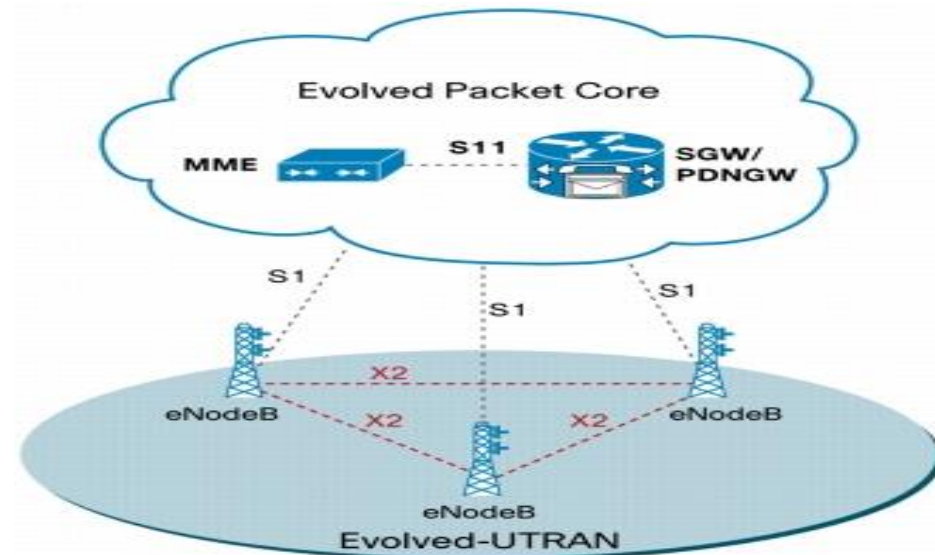

# Introduction to LTE

17

- On the **Network side**, interfaces and protocols have been put in place so that **Data sessions (i.e., active data connections) can be moved seamlessly between LTE, UMTS, GSM and other Non-3GPP Access (i.e., WiMAX)** when the user roams in and out of areas covered by **different air interface technologies**.

- Thus, **LTE-capable devices** must also support **GSM, GPRS, EDGE** and **UMTS** interfaces.

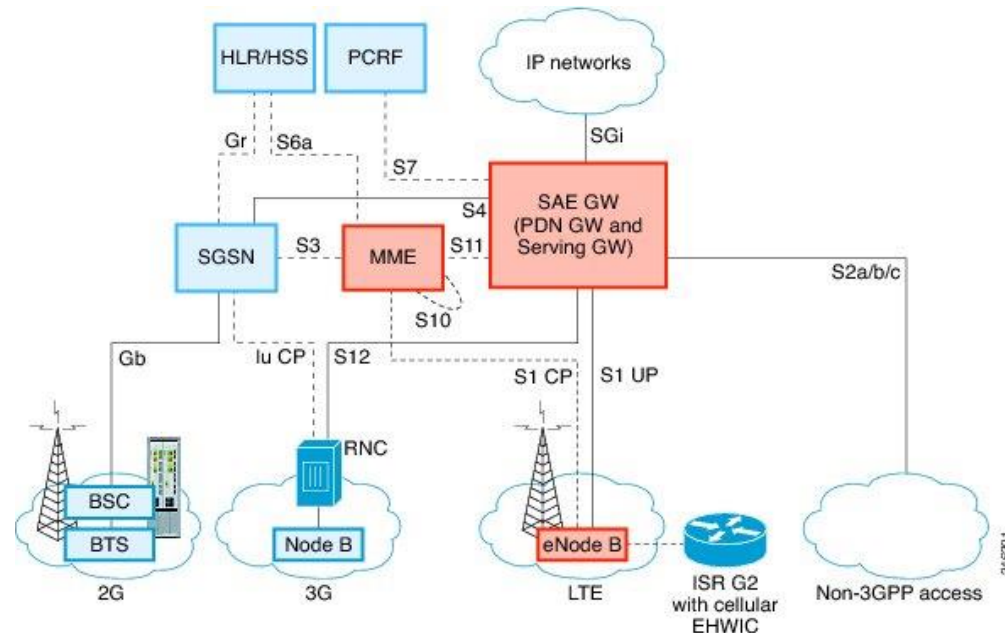

# LTE Network Architecture

## LTE Mobile Devices

18

- In the LTE specifications, as in UMTS, the **Mobile Device** is referred to as the **User Equipment (UE)**
- For LTE, **five (5) different UE classes (categories)** have been defined
- In the **Downlink**, **all the LTE UEs** support **64-QAM** modulation
- In the **Uplink**, **only** the support of the slower but more reliable **16-QAM** is required for UE Classes 1 to 4.

- However, **Class 5** devices have to **support 64-QAM**

- Also **all the LTE UEs** have to **support MIMO transmission**

- **2x2 MIMO** for first LTE UEs

- **4x4 MIMO** for Class 5

Category	1	2	3	4	5
Maximum downlink datarate (20 MHz carrier)	10	50	100	150	300
Maximum uplink datarate	5	25	50	50	75
Number of receive antennas	2	2	2	2	4
Number of MIMO downlink streams	1	2	2	2	4
Support for 64 QAM in the uplink_direction	No	No	No	No	Yes

# LTE Network Architecture

## The eNode-B

19

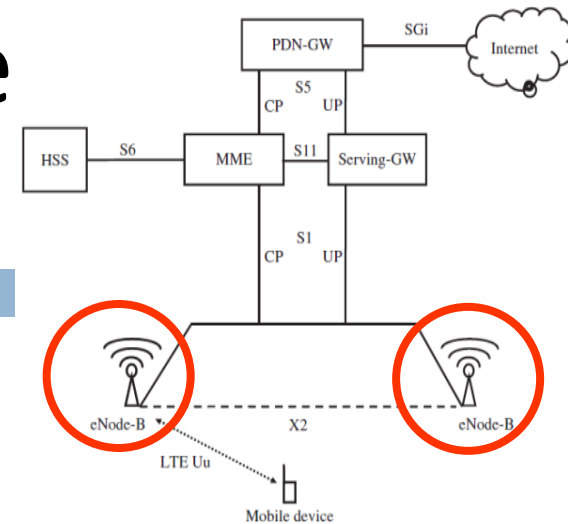

- The **most complex device** in the **LTE network** is the **Base Station**, referred to as **eNode-B (eNB)**.
- Unlike in UMTS, LTE Base Stations **are autonomous units**.
  - ▣ In LTE, it was decided to **integrate most of the functionality (i.e., Radio Resource Management)** that was previously part of the **Radio Network Controller** into **the Base Station** itself.
  - ▣ For example, the **eNode-B decides on its own to handover ongoing data transfers** to a neighboring eNode-B, **a novelty in 3GPP systems**.

# LTE Network Architecture

## The eNode-B

20

- The **air interface** between the eNodeB and the LTE UE is referred to as the **LTE Uu interface** (this interface implements the **OFDM physical Channels**)
- The **interface** between the **eNodeB** and the **Core Network** is referred to as the **S1 interface**.
- The **interface** between **two eNodeBs** is referred to as the **X2 interface**.

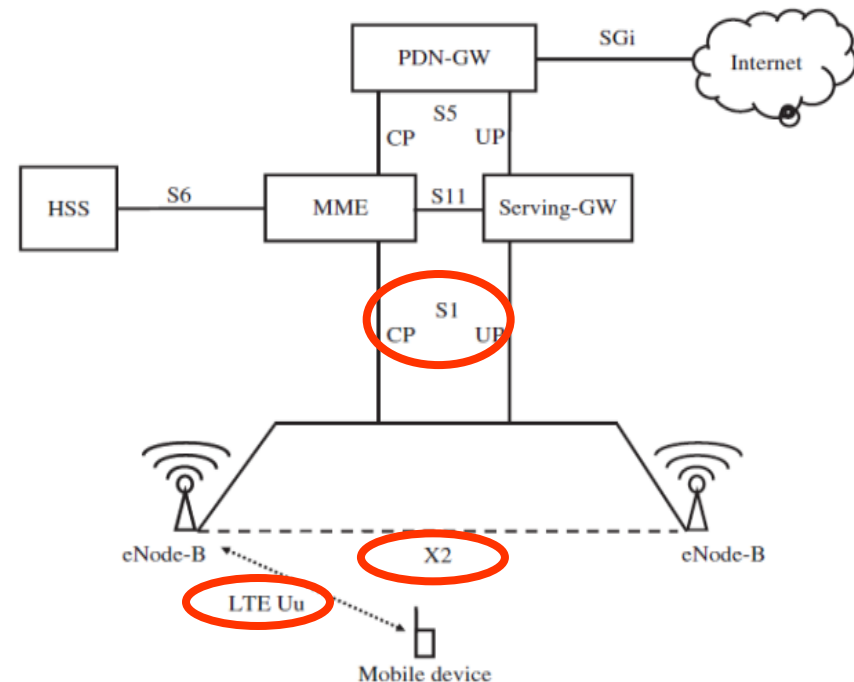

# LTE Network Architecture

## The eNode-B

21

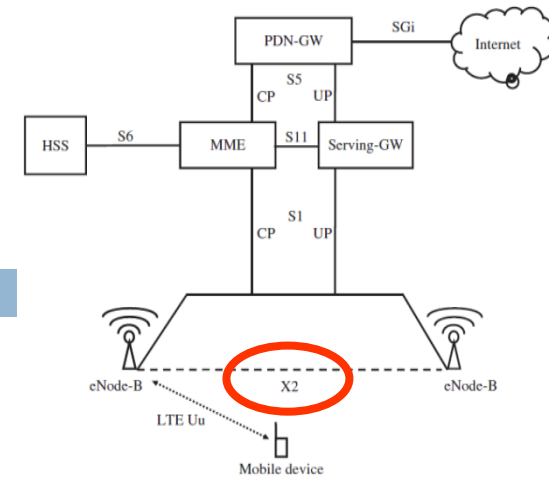

- As LTE Base Stations are **autonomous units**, they **communicate directly with each other** over the **X2 interface** for two purposes:
  1. **Handovers** are now **controlled by the eNodeBs themselves**. If the Target cell is known and **reachable over the X2 interface**, the cells **communicate directly with each other**. Otherwise, the **S1 interface** and the CN are employed to perform the handover.
  2. The **X2 interface** can be used **for Inter-Cell Interference Coordination (ICIC)**. For example, as Mobile Devices can **report, the noise level** at their current location and the **perceived source (i.e., the eNodeB that causes the noise)**, to their **Serving eNodeB**, the **X2 interface** can then be **used** by the Serving eNodeB to **contact the neighboring eNodeB**, in case the Neighbouring eNodeB **causes a lot of noise**, and **agree on methods to mitigate or reduce the noise problem**.

# LTE Network Architecture

## The Mobility Management Entity (MME)

22

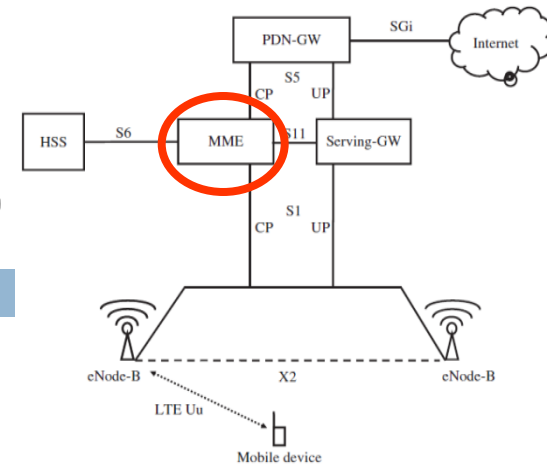

- The eNode-Bs **autonomously handle users** and **their radio connections** once they are established. However **overall User Control is centralized in the Core Network**.
- This is **necessary** as there **needs to be a single point over which data, between the user and the Internet, flows**.
- Further, a **centralized user database (Home Subscriber Server (HSS)) is required**, which **can be accessed from anywhere in the Home Network** and **also from networks abroad in case the user is roaming**.
- The **network node responsible for all signaling exchanges between the Base Stations and the Core Network as well as between the Users and the Core Network is the Mobility Management Entity (MME)**.

# LTE Network Architecture

## The Mobility Management Entity (MME)

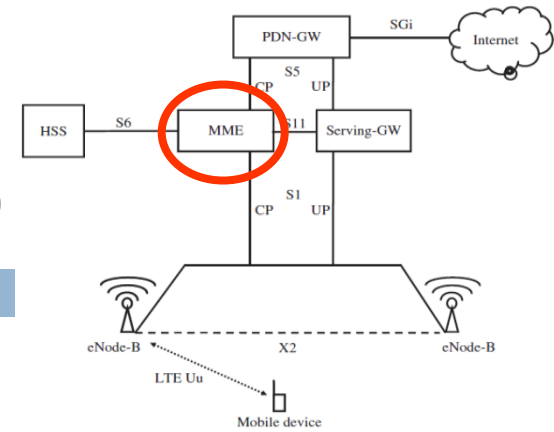

23

- The MME is mainly responsible for:
  - ▣ **User's Authentication:** When a subscriber first attaches to the LTE network the MME requests authentication information from Home Subscriber Server (HSS) and authenticates the subscriber.
  - ▣ **Establishment of bearers:** Establishment of IP tunnels (dedicated to an LTE UE) between the eNode-B and the Packet Data Network Gateway (PDN-GW) which is the Gateway to the Internet.
  - Note that the establishment of the OFDM physical channels over the air interface between the eNode-B and the UE is a responsibility of the eNodeB.



# LTE Network Architecture

## The Mobility Management Entity (MME)

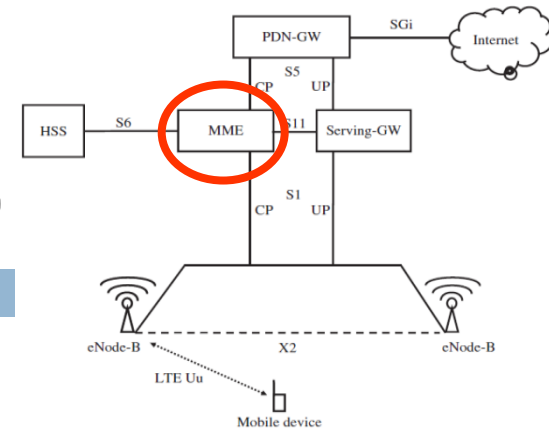

24

- The MME is mainly responsible for:
  - ▣ **Mobility Management:** Locate the UE, by sending a **Paging signal** to the group of Base Stations that belong to the Tracking Area (TA)\* the UE is currently roaming.
  - ▣ **Handover support:** In case no X2 interface is available between the eNodeBs, the MME helps to **forward the handover messages** between the **two eNode-Bs involved**.

*\* Tracking Area (TA): This Area includes a group of Bases Stations (Cells). If the LTE UE is idle, will have to inform the MME about any location update only when it enters a new Tracking Area (TA).*

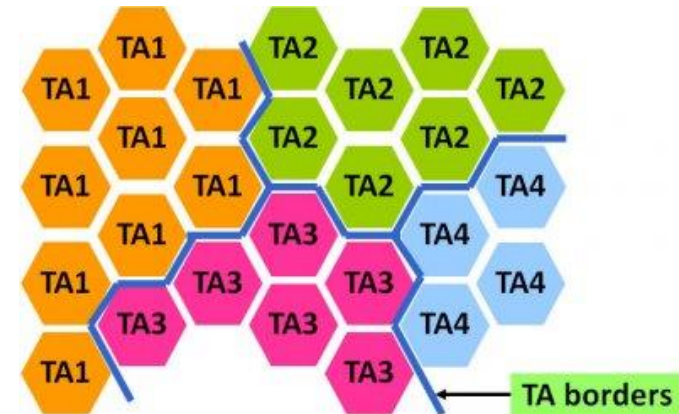

# LTE Network Architecture

## The Mobility Management Entity (MME)

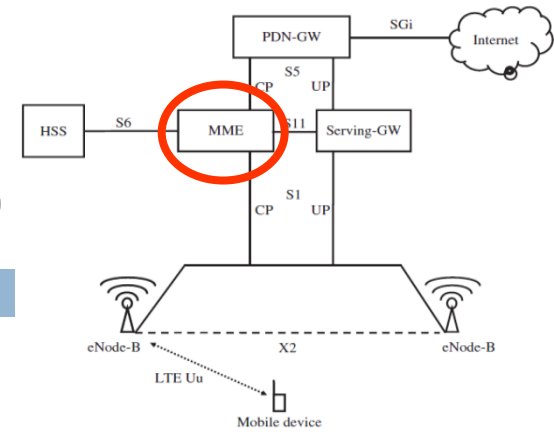

25

- The MME is mainly responsible for:
  - ▣ **Interworking with other radio networks:** When a Mobile Device reaches the **limit of the LTE coverage area**, the eNode-B can decide to **handover the mobile device** to a GSM or UMTS network or instruct it to perform a cell change to a suitable cell. In both cases, the **MME is the overall managing instance** and **communicates** with the GSM or UMTS network components during this operation.
  - ▣ **Billing and Charging:** To charge mobile subscribers for their use of the system, **billing records are created, on the MME**. These are **collected and sent to a charging system**, which **once a month generates an invoice that is then sent to the customer**.

# Key Features of LTE

## Most Important Key Features of LTE:

- **Multicarrier Transmission**
  - ▣ Orthogonal Frequency Division Multiple Access (OFDMA) in the Downlink (DL) Direction
  - ▣ Single Carrier - FDMA (SC-FDMA) in the Uplink (UL) Direction
- **Adaptive Modulation and Coding**
  - ▣ DL and UL modulations: QPSK, 16QAM, and 64QAM
  - ▣ Coding: Convolutional code and Rel-6 Turbo Code
- **Advanced MIMO Spatial Multiplexing**
  - ▣ (2 or 4) x (2 or 4) MIMO Downlink and Uplink supported.
- **Hybrid-Automatic Repeat ReQuest (HARQ)**
  - ▣ For fast reporting and retransmission of packets that received with errors, aiming to minimize the resulting packet delay and jitter.

# Air Interface in LTE

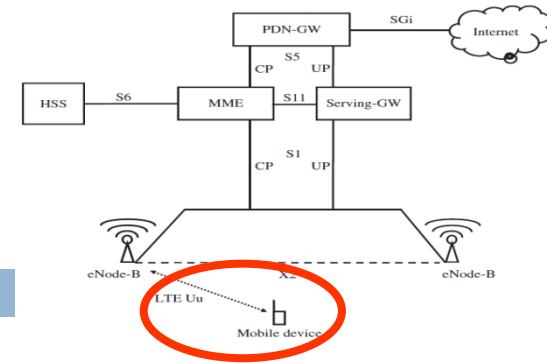

27

- The major evolution in LTE compared to previous 3GPP wireless systems is the **completely revised air interface (based on OFDMA)**.
- When UMTS was designed **an air interface**, based on WCDMA, with a **Carrier Bandwidth of 5 MHz was specified**.
- With today's **Hardware and Processing capabilities**, **Higher data rates can be achieved** by **using an Increased Carrier Bandwidth**.

# Air Interface in LTE

28

- **UMTS**, however, **does not scale** in this regard as the **WCDMA transmission scheme** (being a single carrier transmission scheme) is **not ideal for wider channels**.
  - When the **carrier bandwidth is increased**, the **symbols need to become shorter** (and thus the time between consecutive symbols needs to be reduced) to take advantage of the additional bandwidth (as **more bits will be sent at the same amount of time**).
  - **By increasing the transmission speed** (i.e., Data Rate), which results in a **decrease of the symbol time**, the **negative effect** of the **InterSymbol Interference (ISI)** increases.
  - As a consequence, **CDMA is not suitable for carrier bandwidths beyond 5 MHz**.
- Thus, **Multicarrier Transmission** has been **defined for LTE** to mitigate the problems of **Multipath (Fast) Fading** and **InterSymbol Interference (ISI)** to some degree at the **expense of rising complexity**.

# Air Interface in LTE

## OFDMA for Downlink Transmission

29

- Instead of sending a data stream at a very high speed over a single carrier as in UMTS, **OFDMA splits the data stream into many slower data streams that are transported over many subcarriers simultaneously.**
  - ▣ Carrier Bandwidth: 180 KHz
  - ▣ Subcarrier Spacing (bandwidth): **15 kHz**
  - ▣ The **advantage** of many slow but parallel data streams is that **symbols' duration can be sufficiently long** (even 10 times greater than the Delay Spread caused) to **avoid the effects of multipath transmission** (i.e., InterSymbol Interference (ISI))

# Air Interface in LTE

## OFDMA for Downlink Transmission

30

- Note that **regardless of the overall channel bandwidth (i.e., 1.4 MHz, 5 MHz, 10 MHz, 20 MHz, etc.) the subcarrier spacing (i.e., bandwidth) remains the same (i.e., 15 KHz)**
  - For example, for a **Wider Bandwidth**, the **number of subcarriers is increased** while the **individual subcarrier bandwidth (which is 15KHz) remains the same.**

Bandwidth (MHz)	Number of subcarriers
1.25	76
2.5	150
5	300
10	600
15	900
20	1200

# Air Interface in LTE

## SC-FDMA for Uplink Transmission

31

- For Uplink data transmissions, **the use of OFDMA is not ideal** because of its **high Peak to Average Power Ratio (PAPR)** when the **signals from multiple subcarriers are combined**.
- In practice, the **amplifier in a radio transmitter circuit has to support the Peak Power output** required to transmit the data
- This **Peak Power output value defines the power consumption** of the transmitting device.
- Note that **the Average output power required** for the signal to reach the Receiver **is much lower**.
- Hence, it can be said that the **PAPR of OFDMA is very high**.

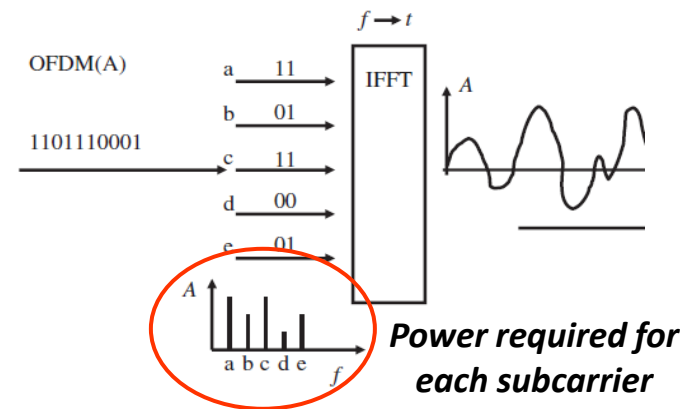

*With OFDMA, Data stream is divided into lower data rate streams and transmitted in a number of subcarriers (a, b, c, d, e)*



# Air Interface in LTE

## SC-FDMA for Uplink Transmission

32

- For a **Base Station**, a high PAPR can be tolerated as **power is not a problem** (power is abundant).
- However, for a **Mobile Device** that is **Battery driven**, the transmitter **should be as efficient as possible**.
- 3GPP has hence decided to use a different transmission scheme, referred to as **Single-Carrier Frequency Division Multiple Access (SC-FDMA)**.
- **SC-FDMA** is a misleading term as **SC-FDMA** is essentially a multicarrier **scheme similar to OFDMA**.

# Air Interface in LTE

## SC-FDMA for Uplink Transmission

33

- **SC-FDMA contains some additional transmission processing steps** beneficial for reducing the PAPR required.
- During these steps, **the information of each bit is distributed onto all subcarriers used for the transmission** reducing in this way the power differences between the subcarriers → In this way **a much lower PAPR than** that obtained with **OFDMA is achieved** (by approximately 2 dB).
- However, the tradeoffs are additional **processing complexity during the transmission** and **lower transmission data rates in the uplink**.

# OFDMA Vs SC-FDMA

34

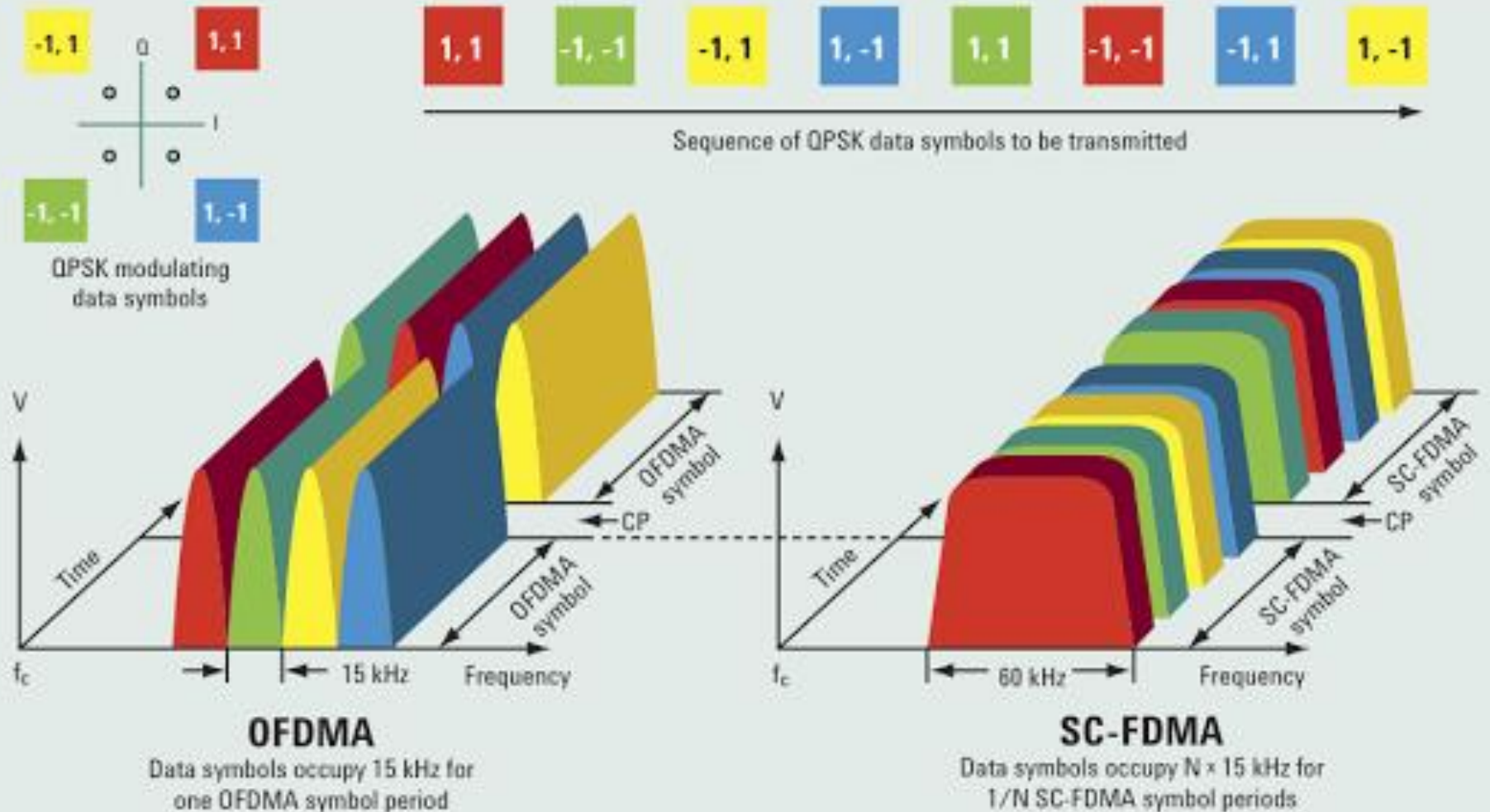

# Symbols, Resource Blocks, Slots, Subframes and Frames

35

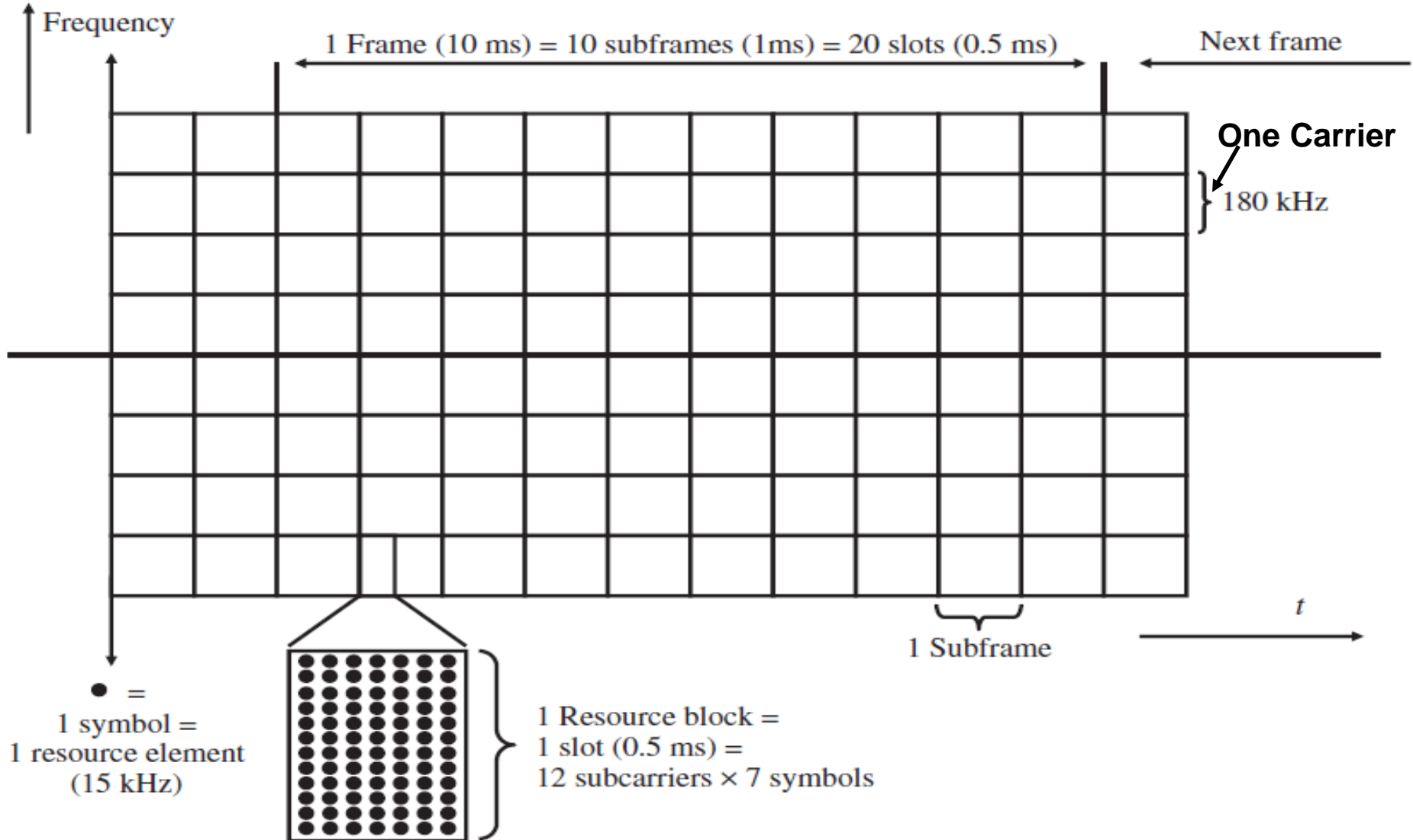

# Symbols, Resource Blocks, Slots, Subframes and Frames

36

- The smallest transmission unit on each subcarrier (of 15KHz wide) is the **symbol** with a length of **66.667 microseconds** ( $10^{-6}$  seconds)
  - **Several bits** can be **transmitted per symbol** depending on the **Modulation Scheme** used.
  - If **radio conditions are excellent**, 64-QAM (Quadrature Amplitude Modulation) is used to transfer 6 bits ( $2^6 = 64$ ) per symbol.
  - Under **less ideal signal conditions**, 16-QAM or QPSK (Quadrature Phase Shift Keying) modulation is used to transfer 4 or 2 bits per symbol.
  - A **symbol** is also referred to as a **Resource Element (RE)**.

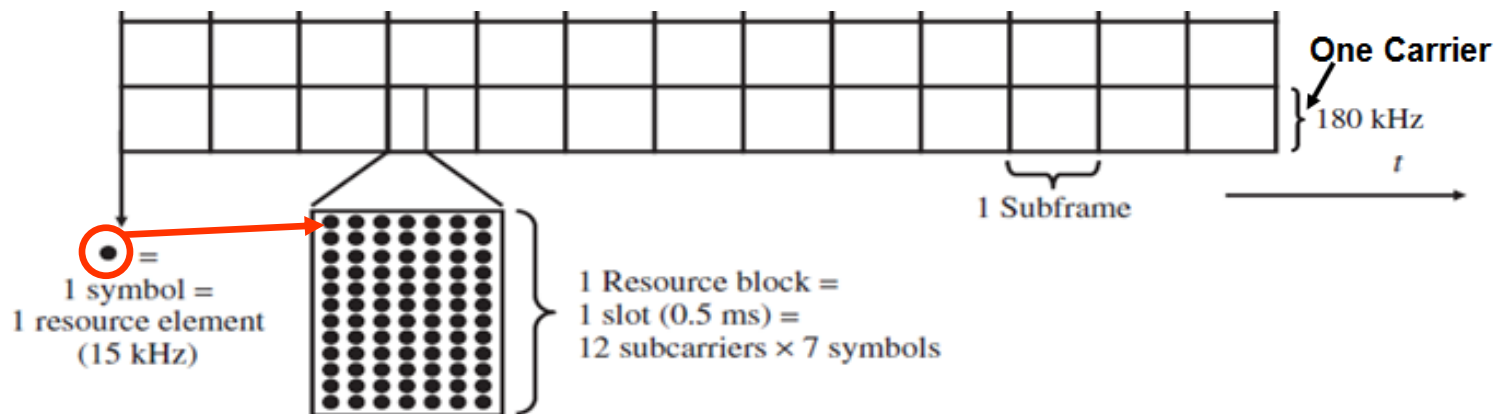

# Symbols, Resource Blocks, Slots, Subframes and Frames

37

- As the **overhead involved in assigning each individual symbol to a certain user would be too great**, the symbols are **grouped together** into a number of different steps. These are:
  - ▣ **Resource Block (RB; 1 slot time that is 0.5 ms)**
  - ▣ **Subframe (2 slots → 2 subsequent RBs):** Subframe represents the LTE scheduling time. That is every 1 ms the eNodeB schedules the parallel RBs to one or more Users.
  - ▣ **LTE Radio Frame (10 Subframes; 20 slots → 20 subsequent RBs)**

# Symbols, Resource Blocks, Slots, Subframes and Frames

38

- Resource Block (RB)
  - ▣ **Seven (7) consecutive symbols on 12 subcarriers are grouped into a Resource Block (RB).**
  - ▣ **A Resource Block (RB) occupies exactly one slot with a duration of 0.5 milliseconds**

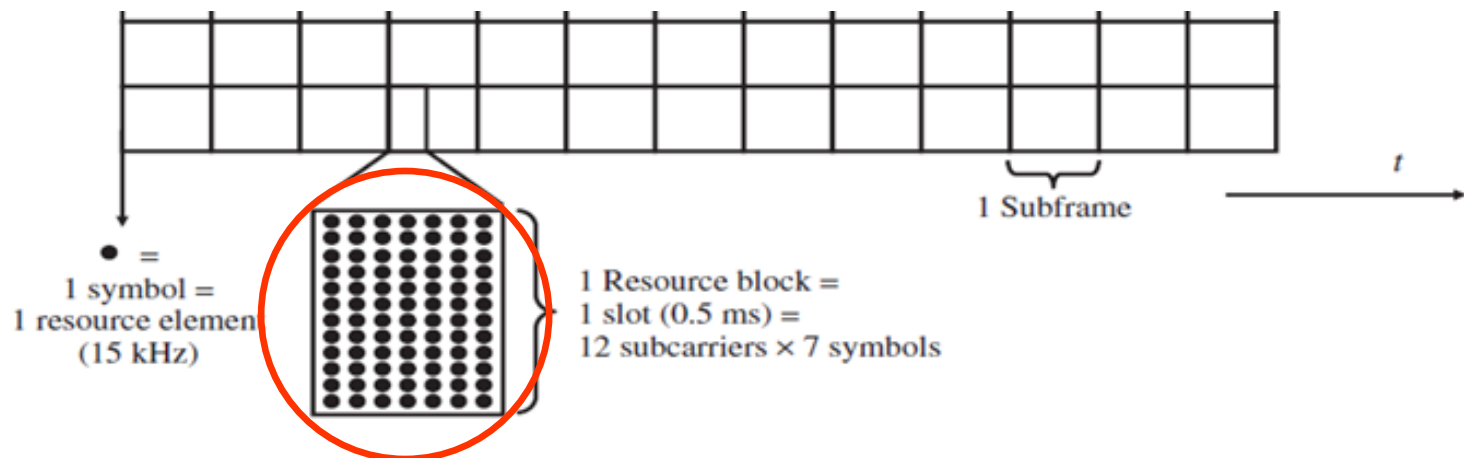

# Symbols, Resource Blocks, Slots, Subframes and Frames

39

## □ Subframe

- Two (2) slots **form a Subframe** with a duration of **1 millisecond** ( $10^{-3}$  sec)
- A Subframe represents the LTE scheduling time, which means that **at each millisecond** the **eNode-B** decides as to **which users are to be scheduled** and **which Resource Blocks (RBs)** are **assigned to which user**.

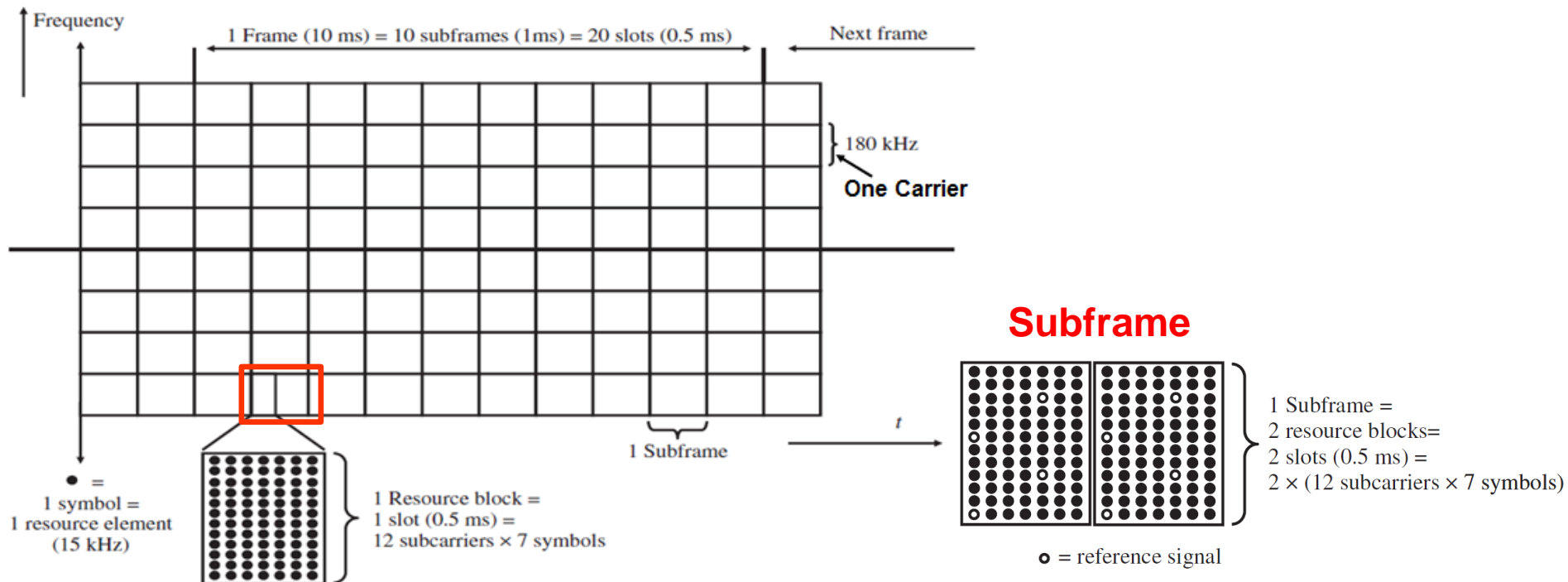



# Symbols, Resource Blocks, Slots, Subframes and Frames

Bandwidth (MHz)	Number of subcarriers
1.25	76
2.5	150
5	300
10	600
15	900
20	1200

40

- The **number of parallel Resource Blocks (RBs)** in each **Subframe period** depends on the **system Bandwidth**.
- For example, if a **10-MHz bandwidth carrier** is used, **600 subcarriers are available**. As a **Resource Block (RB)** includes **12 subcarriers**, a **total of 50 parallel RBs** are available in each slot of a Subframe.
- As a Subframe is **formed by two slots** (and each slot includes one RB), **100 RBs** can be **scheduled for one or more users per Subframe time**.

*Note that on the figure on the right (for simplification) only eight parallel Resource Blocks are shown in the y-axis. On a 10-MHz carrier, for example, 50 Resource Blocks are used in parallel in each slot of a Subframe.*

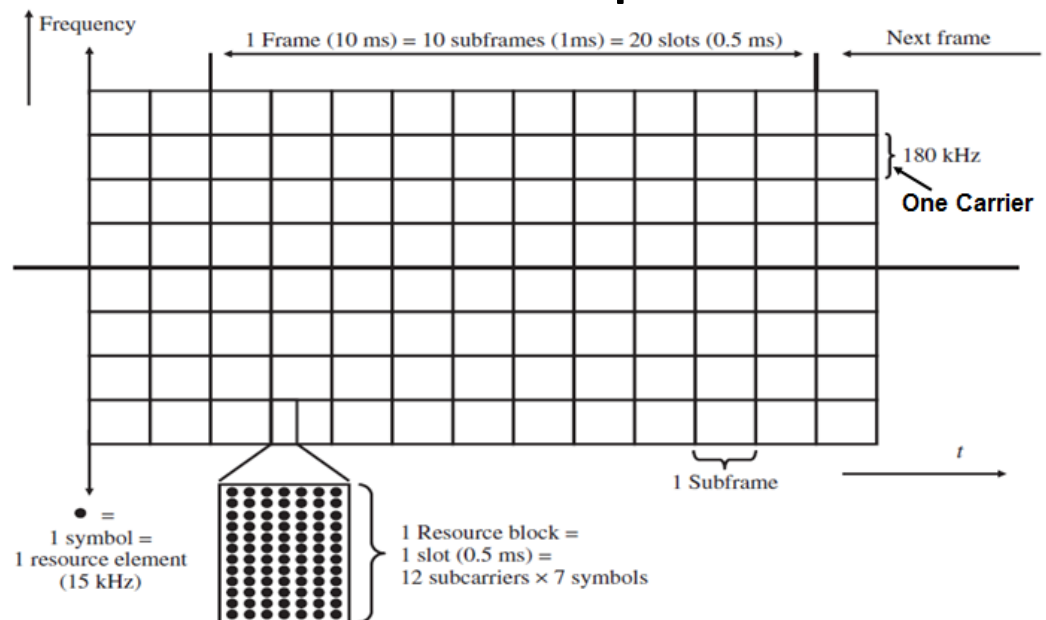

# Symbols, Resource Blocks, Slots, Subframes and Frames

41

## □ LTE Radio Frame

- Finally, **10 Subframes** are **combined** into an **LTE Radio Frame**, which has a length of **10 milliseconds**.
- **LTE Radio Frames** are also used for the **scheduling** of periodic **System Information (SI)** conveying **information that is required by all UEs** that are currently in the cell.

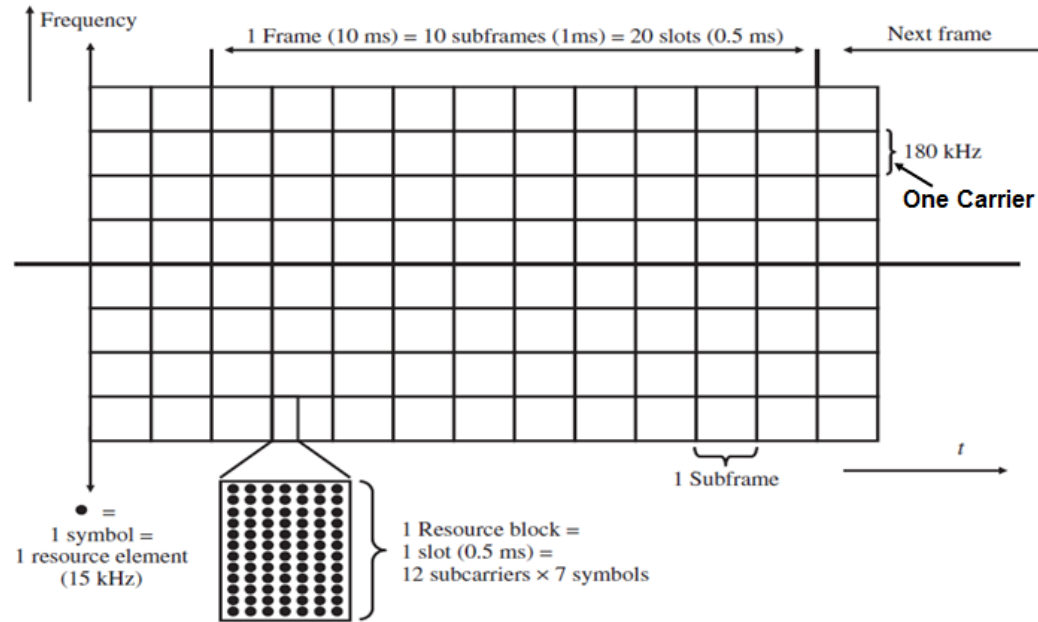

System information blocks and content overview

Message	Content
MIB	Most essential parameters required for initial access
SIB 1	Cell identity and access-related parameters and scheduling information of system information messages containing the other SIBs
SIB 2	Common and shared channel configuration parameters
SIB 3	General parameters for intrafrequency cell reselection
SIB 4	Intrafrequency neighbor cell reselection information with information about individual cells
SIB 5	Interfrequency neighbor cell reselection parameters
SIB 6	UMTS inter-RAT cell reselection information to UMTS
SIB 7	GSM inter-RAT cell reselection information to GSM
SIB 8	CDMA2000 inter-RAT cell reselection information
SIB 9	If the cell is a femto cell, i.e. a small home eNode-B, this SIB announces its name
SIB 10	Earthquake and tsunami warning system (ETWS) information
SIB 11	Secondary ETWS information
SIB 12	Commercial mobile alert system (CMAS) information

# LTE Channel Structure

## Type of Channels

42

*Note: LTE defines same type of channels as WCDMA/HSPA*

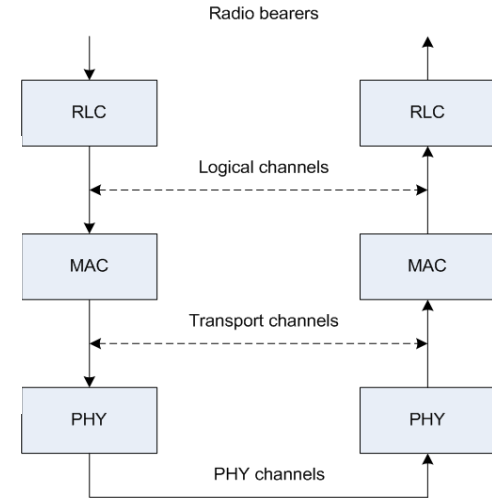

- Logical channels
  - **Formed by RLC** (Radio Link Control) layer
  - Characterized by the **type of information it carries (what)** (i.e., Control channel used to carry Control Information, a traffic channel is used for the user data)
- Transport channels
  - **Formed by MAC** (Medium Access Control) layer
  - Characterized by **how the data will be transmitted** (i.e., defines the Transport Format (TF)\*) over the Radio Interface (i.e., the Physical Layer).
- Physical channels
  - **Formed by PHY** (Physical Layer – **OFDM Channels**)
  - Consist of a group of **RBs** that will **be assigned to the users** (the data in the RBs will be transmitted based on the TF selected by the MAC layer)

*\*Transport Format (TF): Specifies how the data is to be transmitted over the radio interface (e.g., Modulation Scheme, Coding, Antenna Mapping (e.g., type of MIMO used))*

# LTE Channel Model

## Downlink Direction

43

- All Downlink **Control Signaling** and **User Data traffic** are organized in:
  - **Logical channels** → Determines the Data and type of data that will be transmitted; e.g., Control signaling, User Traffic
  - **Transport channels** → Determines how the data will be transmitted; e.g., Multiplexing, Transport Format that will be used
  - **Physical channels** → Determines the RBs that will be assigned to the users for the data to be transmitted

# LTE Channel Model

## Downlink Direction

44

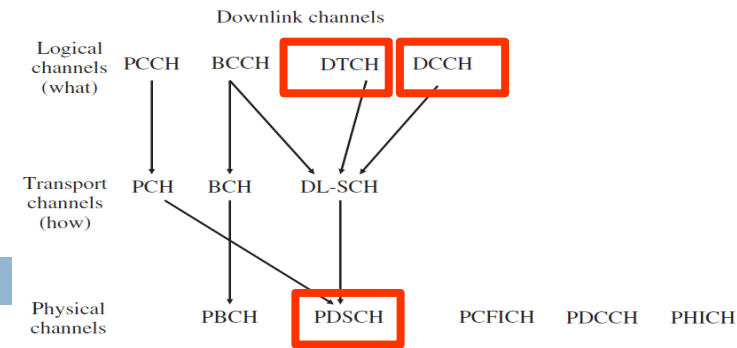

- On the **Logical Layer**, data (user traffic) for each user is transmitted in a **Logical Dedicated Traffic Channel (DTCH)**
  - **Each User** has an **individual DTCH**.
- A UE that has been assigned a DTCH also requires a **Dedicated Control Channel (DCCH)** for the **management of the connection**.
  - Here, the control signaling that is required, for example, **for handover control, channel reconfiguration**, is sent.
- On the air interface (i.e., on the **Physical layer**), all **Dedicated Channels** are **mapped to a single shared channel** that **occupies all Resource Blocks (RBs)** that will be assigned to the users (this channel is the **Physical Downlink Shared Channel (PDSCH)**).

# LTE Channel Model

## Downlink Direction

45

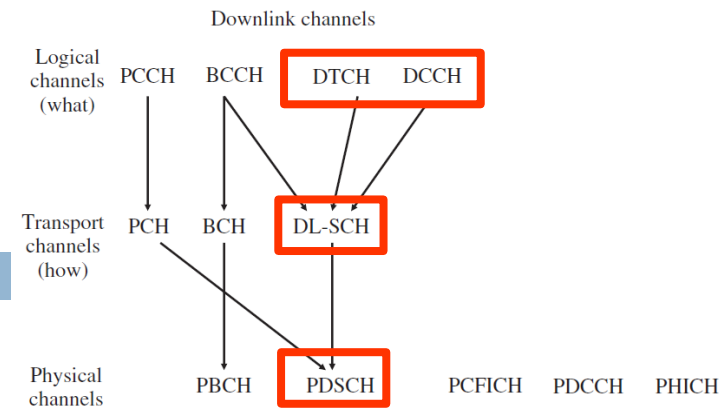

- The **DTCH** and the **DCCH** assigned to each user are **mapped to individual Resource Blocks** in the **Physical Downlink Shared Channel (PDSCH)** in two steps.
- In the first step, the logical DTCH and DCCH of each user **are multiplexed (into a data stream)** to the Transport layer in the **Downlink Shared Channel (DL-SCH)** and the **Transport Format (Modulation, Coding and MIMO used)** that will be used during their transmission is determined.
- In the second step, this data stream is then mapped to the **Physical Downlink Shared Channel (PDSCH)** (i.e., to the Resource Blocks that are allocated to the users)
  - **Which Resource Blocks are assigned to which user is decided** by the **scheduler in the eNodeB** for each **Subframe**, that is, once per millisecond.

# LTE Channel Model

## Downlink Direction

46

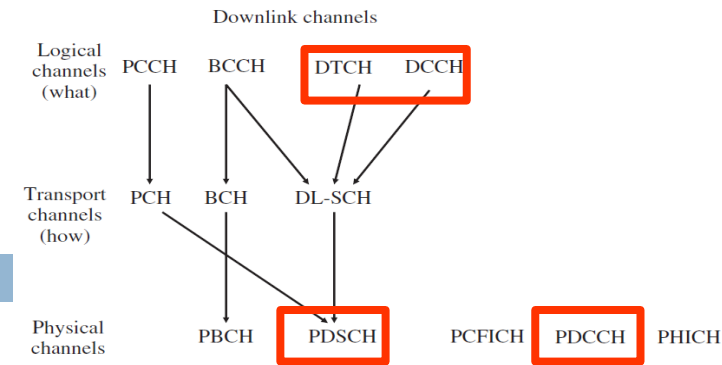

- Note that **ALL** the **DTCH** and **DCCH** of all the users are mapped to a single **PDSCH**.
- Therefore, a mechanism is required to **indicate to each UE**:
  - ▣ **When and where (i.e., which RBs in the Subframe), what kind of data (i.e., traffic or control) is scheduled for them and how (i.e., the Transport Format (TF) that will be used) data are transmitted to them** on the **PDSCH** in the **Downlink Direction**.
  - ▣ **Which RBs is allowed to use in the Uplink direction.**
- This is done via **Physical Downlink Control Channel (PDCCH)** messages.

# LTE Channel Model

## Uplink Direction

47

- In the **Uplink direction**, a similar channel model is used as in the downlink direction.
- The most important channel is the **Physical Uplink Shared Channel (PUSCH)**.
- The **PUSCH** main task is to carry the **User Data Traffic** and **Control Signaling** as well as Downlink **Signal Quality Feedback**.
- **Signal Quality Feedback** will be considered by the eNodeB to **adapt** the **Transport Format** that will be used in the **Downlink** for the specific UE (for the subsequent RBs) according to its downlink channel conditions.

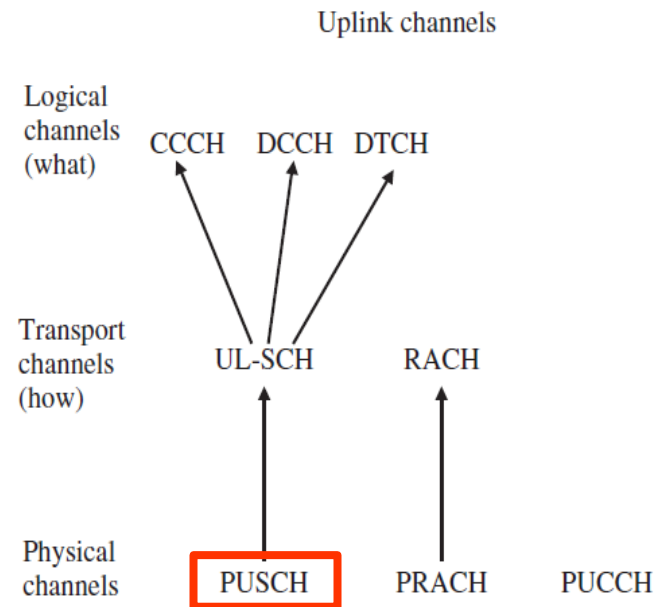



# LTE Channel Model

## Uplink Direction

48

- When a Mobile Device **has been granted resources** (i.e., RBs have been reserved and assigned for it in the next 1ms), the PUSCH is used for **transmitting the user data traffic** (over the DTCH) and also for **transmitting Control Signaling Data** (over the DCCH)
- The **Control Signaling Data** is required to
  - **Maintain the Uplink connection** and
  - **Optimize the data transmission** over the **Downlink connection**.

# LTE Channel Model

## Uplink Direction

49

- The main **Control Signaling Data** sent in the PUSCH is:
  - ▣ The **Channel Quality Indicator (CQI)** that the **eNode-B considers to adapt the Modulation and Coding Scheme** for the **Downlink** direction.
  - ▣ **MIMO-related** parameters (**Rank Indicator (RI)**) that the **eNode-B** can use for **adapting the MIMO transmission** in the **Downlink** direction (i.e., number of independent data streams the UE can receive based on its channel conditions).
    - **Rank 1** signifies a **single-stream transmission** (i.e., a single stream is sent over multiple antennas which **boost the SNR** at the UE)
    - **Rank 2** signifies a two-stream MIMO transmission (i.e., two independent data streams are sent over the same air interface **increasing the achievable throughput**).

# MIMO Transmission & Adaptive Modulation and Coding

50

- In addition to **Adaptive Modulation and Coding**, LTE allows the use of **Multi-Antenna techniques**, also referred to as **Multiple Input Multiple Output (MIMO)** in the Downlink direction.
- The basic idea behind MIMO techniques is to **send several independent data streams** over the **same air interface channel simultaneously (e.g., Spatial Multiplexing)**.
- In Spatial Multiplexing, a high-data rate signal is split into multiple lower-rate streams and **each stream** is transmitted from a **different transmit antenna** in the **same frequency channel**.

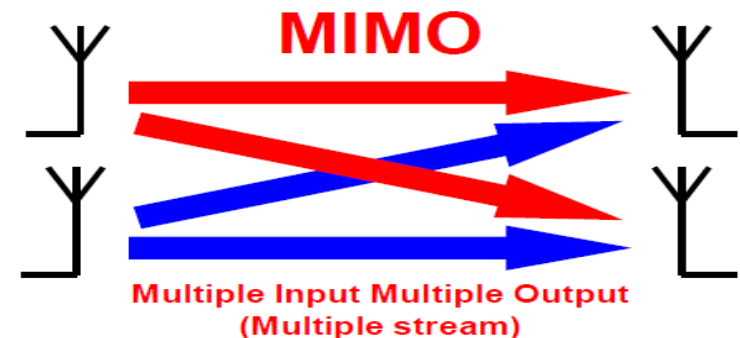

# MIMO Transmission & Adaptive Modulation and Coding

51

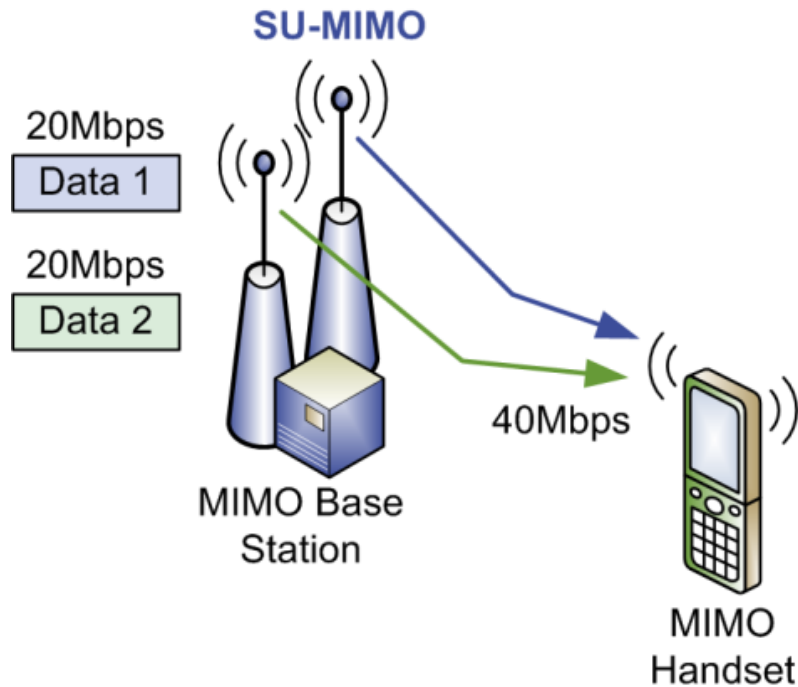

## Single User – MIMO

**(SU-MIMO):** “Conventional” MIMO. One user gets the full benefit of the increased throughput.

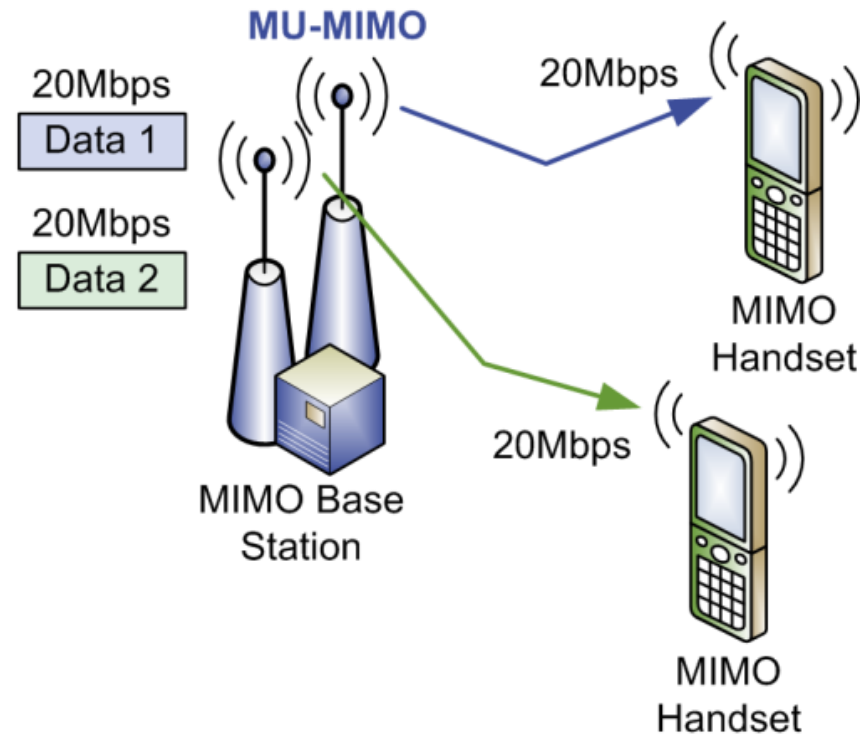

## Multi User – MIMO

**(MU-MIMO):**  
The BS schedules two users to be served at the same time.

# MIMO Transmission & Adaptive Modulation and Coding

52

- Higher Order Modulation scheme (i.e., **64QAM**) and two stream operation **MIMO** (Rank 2) is only used for the **Physical Downlink Shared Channel (PDSCH)** and only to transmit those Resource Blocks assigned to users that **experience very good signal conditions**.
- For other channels (i.e., the BCH which carries the **Master Information Block (MIB)** including the most essentials parameters required for initial access), only **single-stream operation** with a **Robust Modulation (i.e., QPSK)** and **Coding** is used → This is done because the eNode-B has to ensure that the **data transmitted over those channels** can reach all Mobile Devices **independent of their location and current signal conditions**.

# MIMO Transmission & Adaptive Modulation and Coding

53

- Once **the interference gets too strong** (this is indicated in the CQI sent by the UE to the eNodeB), the **Modulation scheme has to be lowered**, that is, **instead of using 64-QAM and two stream operation MIMO together**, the Modulation is **reduced to 16-QAM and single stream operation MIMO**.
- ▣ The **Transport Format** and the MIMO transmission that will be used depends on the characteristics of the downlink channel, and it is the **eNodeB's** task to make a **proper decision on how to transmit the data**.

# MIMO Transmission & Adaptive Modulation and Coding

54

- **Only in very ideal conditions**, that is, no interference and very short distances between the Transmitter and the Receiver, can **64-QAM** and **MIMO** be **used simultaneously**.
- As **Modulation and Coding** and the **use of MIMO** can be **adapted every millisecond (scheduling time of RBs to the UEs)** on a per device basis, the system can **react very quickly to changing radio conditions** (e.g., like the Fast Power Control used in UMTS).

# MIMO Transmission & Adaptive Modulation and Coding

55

- In the LTE specifications, the term **'Rank'** is often used to **describe the use of MIMO. E.g.,**
  - ▣ **Rank 1** signifies a **single-stream transmission** (i.e., a single stream is sent over multiple antennas which **boost the SNR** at the UE)
  - ▣ **Rank 2** signifies a two-stream MIMO transmission (i.e., two independent data streams are sent over the same air interface **increasing the achievable throughput**).



# MIMO Transmission & Adaptive Modulation and Coding

56

- The UE, **every one millisecond**, based on its downlink channel conditions, sends to the eNode-B (along with other control information) a **Rank Indicator (RI)** and a **Channel Quality Indicator (CQI)**.
- ▣ The **RI** informs the eNode-B about the **number of data streams that can be sent over the channel** from the receiver's point of view.
- ▣ The **CQI** information is **considered by the eNode-B to decide as to which modulation** (QPSK, 16-QAM, 64-QAM) and **which coding rate**, that is, the ratio between user data bits and error detection bits in the data stream that should be used for the transmission.

# Ερωτήσεις;

58

# Additional Slides

# 3GPP Evolution

59

- **2G**: Started years ago with GSM (Mainly voice, SMS) → ~ 1992
- **2.5G**: Added Packet Services (GPRS, EDGE) → ~ 2000
- **3G**: Added 3G (WCDMA) Air Interface (UMTS) → ~ 2001
  - 3G Architecture evolved to:
    - Support of both 2G/2.5G and 3G Access
    - Support Handover between GSM and UMTS technologies
  - 3G Extensions to Increase Bit Rates and User Experience: → ~ 2006
    - HSPA (up to 14.4 Mbps), HSPA+ (up to 42 Mbps)
- **4G** (3.9G – 4G; Heterogeneous Networks): Redesigned the **Radio Network** (based on OFDMA Air Interface; Flat Architecture) and the **Core Network** (New All-IP Core Network with fewer nodes) ~ 2012
  - Long Term Evolution (LTE) and Long Term Evolution Advanced (LTE Advanced)
- **5G**: Future Networks. Demands for new architectures, methodologies and technologies, to support the high data traffic and massive device support foreseen by 2020.

# 3GPP Evolution (UMTS Releases)

60

Release	Standardized	Commercial	Major features
3GPP R99	1999 (WCDMA)	2000	<b>UMTS/WCDMA, Packet Data Bearer services</b> , 64 kbit/s CS, 384 kbit/s PS, Call services: Compatible with GSM
3GPP R5	2002 (WCDMA)	2006	<b>HSDPA, IP Multimedia Subsystem (IMS)</b> , IPv6, IP transport in UTRAN, Improvements in GERAN,
3GPP R6	2004 (WCDMA)	2007	<b>Multimedia Broadcast and Multicast System (MBMS), HSUPA</b> , Improvements in IMS, Fractional DPCH
<b>3GPP R7</b>	2007 (WCDMA)	2008	<b>64 QAM , DL MIMO, VoIP over HSPA</b> , CPC - Continuous Packet Connectivity, FRLC - Flexible RLC
<b>3GPP R8</b>	2008 (WCDMA)	2010	<b>HSPA+, HSUPA 16QAM</b>
<b>3GPP R8 (LTE)</b>	2008 ( <b>OFDM</b> )	2010	<b>New air interface (OFDM/SC-FDMA), New Core Network</b>

- Through 3GPP standardization efforts, **3G continues to progress gracefully evolving into 4G** starting from **Release 7** and **Release 8**.
  - ▣ **Data Rates:** R99: 0.4Mbps UL, 0.4Mbps DL, R5: 0.4Mbps UL, 14Mbps DL, R6: 5.7Mbps UL, 14Mbps DL, R7: 11Mbps UL, 28Mbps DL, R8: 50Mbps UL on LTE, 160 Mbps DL on LTE, 42Mbps DL on HSPA

# 3GPP Evolution

61

- With Release 7 and Release 8 there are **two branches of the standards:**
  - ▣ HSPA: Gradual performance improvements at **lower incremental costs (as the same infrastructure is used)**
  - ▣ LTE: Revolutionary changes with **significant performance improvements**, but with higher cost.
  - First step Towards IMT advanced, specifying the requirements towards a 4G Wireless Networks.

# 3GPP Evolution (LTE Releases)

62

Release	Standardized	Major features
3GPP R8 (LTE)	2008	Multi antenna support (MIMO), Channel Dependent Scheduling, Bandwidth Flexibility, ICIC (Intercell Interference Coordination), Hybrid ARQ, FDD + TDD support
3GPP R9 (LTE)	2009	Dual Layer Beam Forming, Network based UE positioning, MBSFN (Multicast/Broadcast Single Frequency Network)
<b>3GPP R10 (LTE) LTE Advanced</b>	2010	Multi Antenna Extension, Relaying, Carrier Aggregation, Heterogeneous Networks (HetNet's)

- ❑ LTE has an **“Evolution Path” of its own**
- ❑ The evolution is **towards LTE Advanced (4G)**

# LTE Main Features

63

Parameter	Details
Peak DL speed with 64QAM in Mbps	100 (SISO), 172 (2x2 MIMO), 326 (4x4 MIMO)
Peak UL speeds(Mbps)	50 (QPSK), 57 (16QAM), 86 (64QAM)
Data Type	All Packet Switched data → Voice must use VoIP. No Circuit Switched Services (Voice or Data) are supported.
Flexible Channel Bandwidth (MHz)	1.4, 3, 5, 10, 15, 20 (Higher Bandwidth → Higher Data Rates)
Duplex Schemes	FDD and TDD
Mobility	Maximum Performance for low mobility users (0 - 15 km/h) High Performance for 15 - 120 km/h Maximum supported speed 500km/h
Reduced Latency	User plane (data traffic): < 5ms Control plane (control traffic): < 50ms
Spectral Efficiency (compared to Release 6 HSPA)	Downlink: 3 - 4 times better throughput than Rel 6 HSDPA Uplink: 2 - 3 times better throughput Rel 6 HSUPA
Access Schemes	OFDMA (Downlink) SC-FDMA (Uplink)
Modulation Types Supported	QPSK, 16QAM, 64QAM (Uplink and Downlink)



# 3GPP Evolution

## LTE-Advanced: Technology Evolution Towards 4G

64

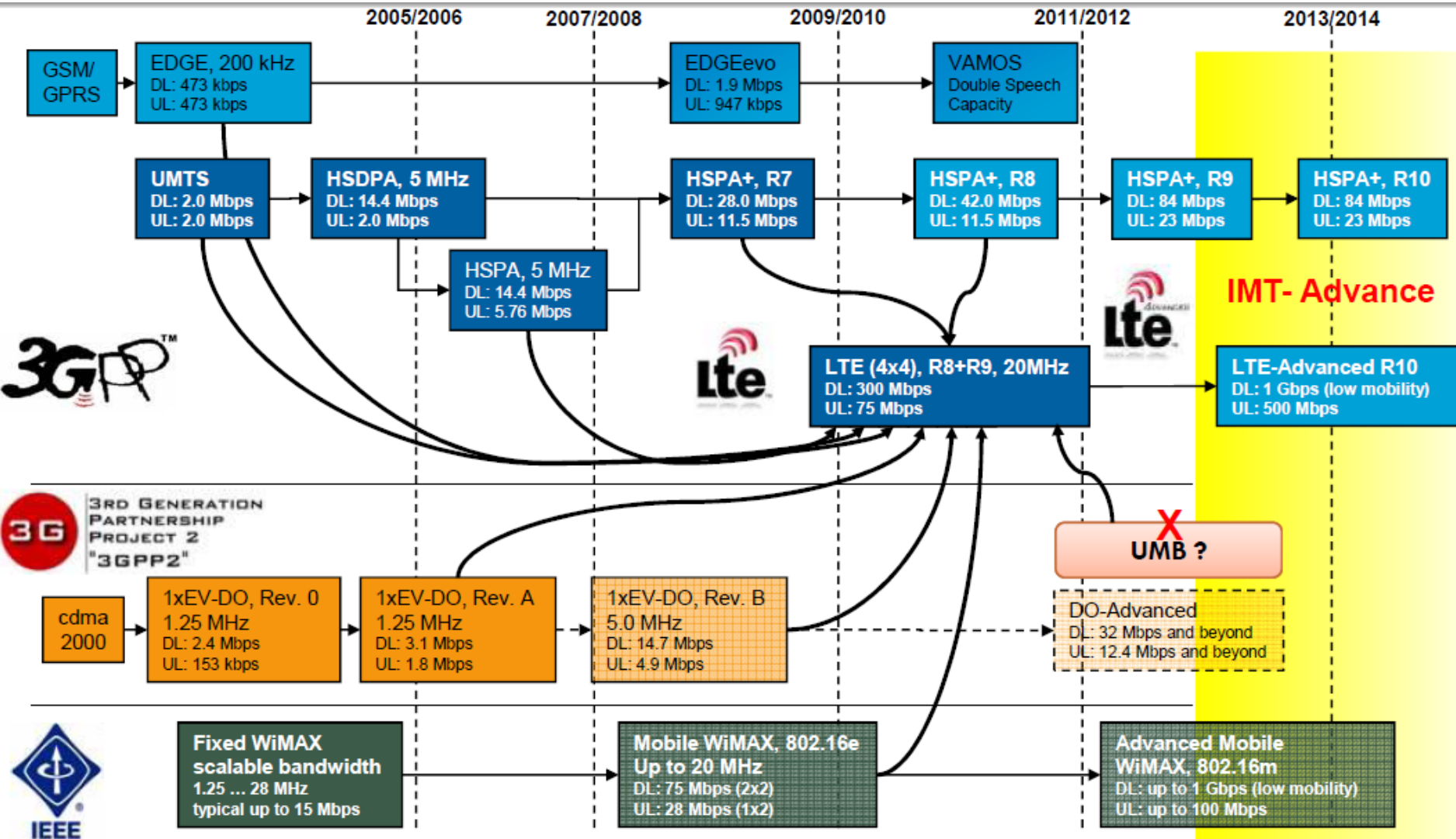

# Multipath Fading

- ❑ Multipath fading can be observed when radio waves bounce off objects on the way from transmitter to receiver, and hence the receiver does not see one signal but several copies arriving at different times.
- ❑ As a result, parts of the signal of a previous transmission step (symbol) that has bounced off objects and thus took longer to travel to the receiver overlap with the radio signal of the current transmission step that was received via a more direct path.
- ❑ The shorter a transmission step (i.e., the shorter the symbol time), the more the overlap that can be observed and the more difficult it gets for the receiver to correctly interpret the received signal.

# Introduction to LTE

- **Long Term Evolution (LTE)**, as specified in **3GPP Release 8** (standardized on 2008 and commercialized on 2010), was a **new beginning** and also a **foundation for further enhancements**.
- With **3GPP Release 10**, new ideas (e.g., Carrier Aggregation – up to 100 MHz Carrier Bandwidth, 8 x 8 MIMO, etc.) to **further push the limits are specified** as part of the **LTE-Advanced** project to comply with the **International Telecommunication Union’s (ITU’s) IMT-Advanced** requirements for **4G Wireless Networks (Heterogeneous Networks)**

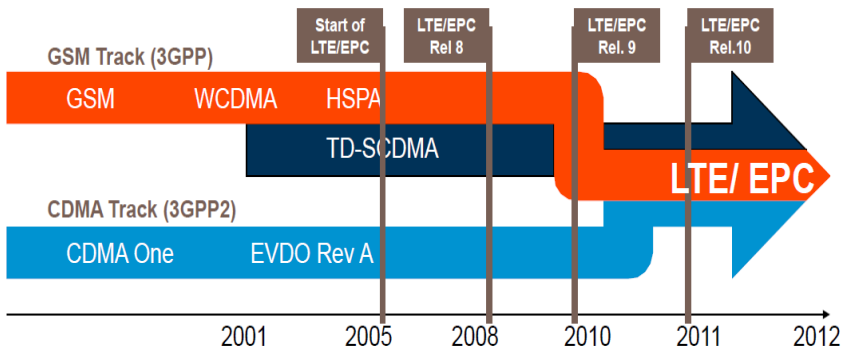

		LTE	LTE-Advanced	IMT-Advanced
		3GPP Release 8	3GPP Release 10	International Telecommunications Union "True 4G"
Peak Data Rate	DL	300 Mbps	1 Gbps	100 Mbps (high mobility)
	UL	75 Mbps	500 Mbps	1 Gbps (low mobility)
Peak Spectrum Efficiency [bps/Hz]	DL	15	30	15
	UL	3.75	15	6.75
Tx Bandwidth	UL & DL	Up to 20 MHz	Up to 100 MHz	Up to 40 MHz

# LTE Network Architecture

67

- **Long Term Evolution (LTE)** encompasses the **evolution of the radio access** through the **E-UTRAN** and the **Non-Radio aspects** under the term **System Architecture Evolution (SAE)**
- At a high-level, the LTE network is comprised of the:
  - Core Network (CN), called **Evolved Packet Core (EPC)** in SAE.
  - Radio Access Network called Enhanced UTRAN (**E-UTRAN**)
- **CN is responsible** for the overall **control of the UE** and the **establishment of the bearers**. → A **bearer** is an **IP packet flow** with a **defined QoS** between the **Gateway** (in the Core Network) and the **User Equipment (UE)**

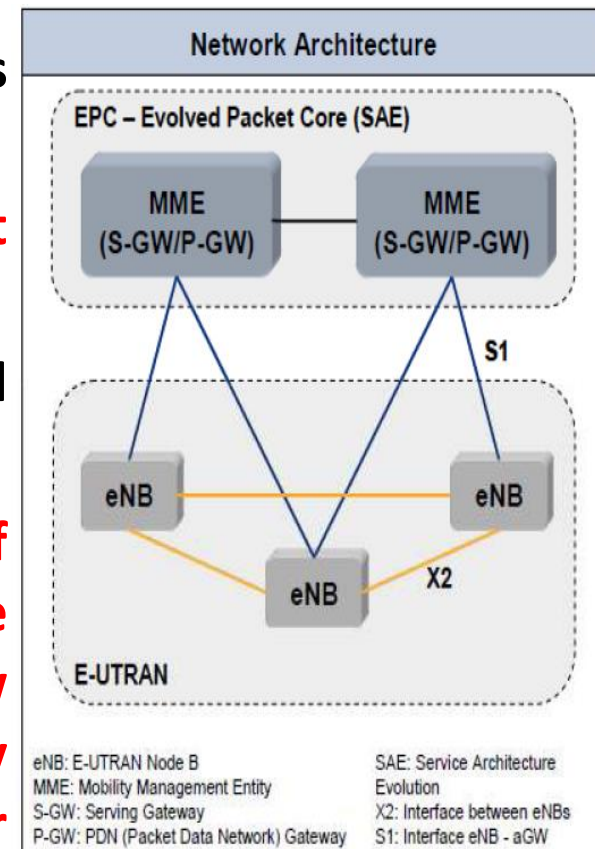

# LTE Network Architecture

## Service Architecture Evolution (SAE)

68

- The general **LTE network architecture** is similar to that of **UMTS**.
- In principle, the network is separated into a **Radio Network part** and a **Core Network part**.
- However, the **number of logical network nodes**, has been **reduced to simplify the overall architecture** and **reduce cost and latency** in the network.

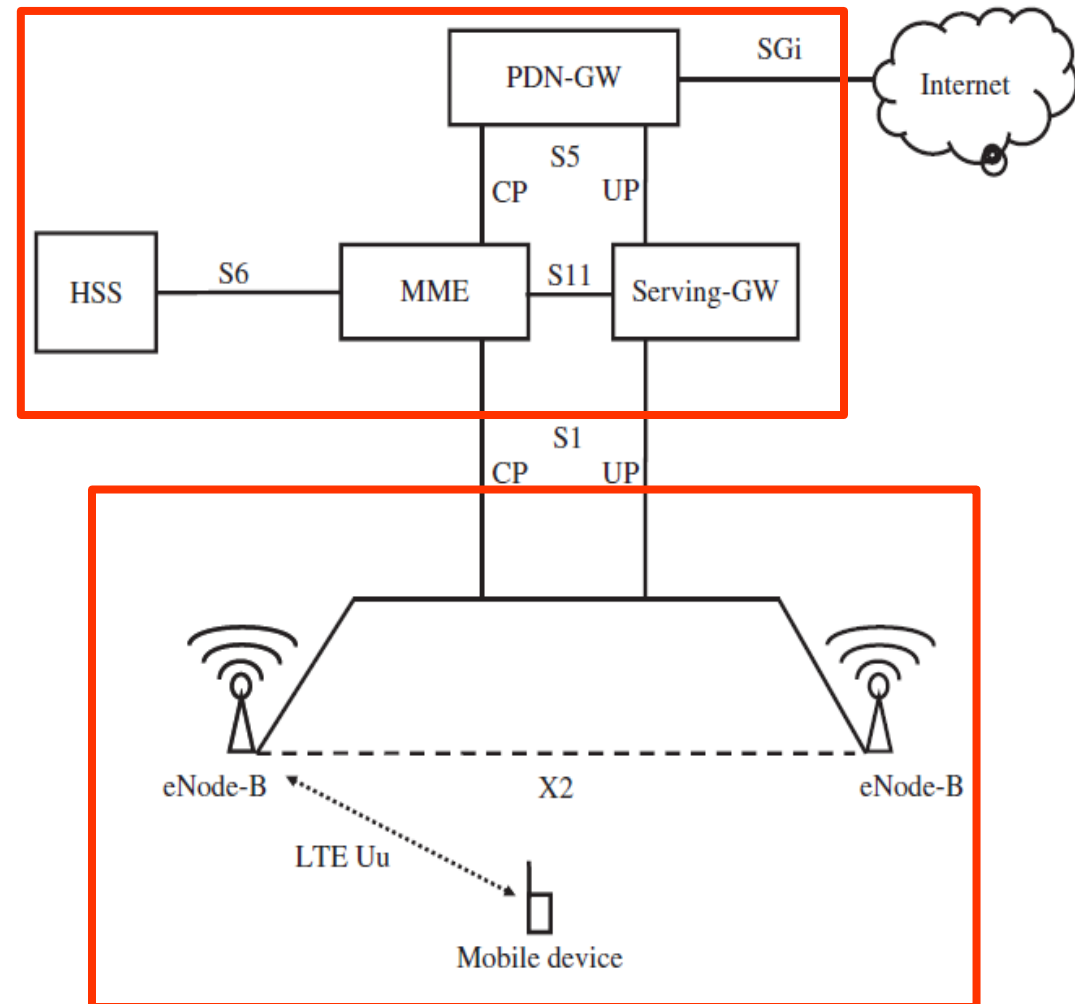

# LTE Network Architecture

## Service Architecture Evolution (SAE)

69

- The **main logical nodes** in the Evolved Packet Core (EPC) are:
  - Packet Data Network Gateway (**PDN-GW**)
  - Serving Gateway (**S-GW**)
  - Mobility Management Entity (**MME**)
- EPC also includes other nodes and functions, such as the **Home Subscriber Server (HSS)**
- E-UTRAN solely contains the evolved Base Stations, called **eNodeB** or eNB
- The **LTE Mobile Device** is referred as the **User Equipment (UE)**

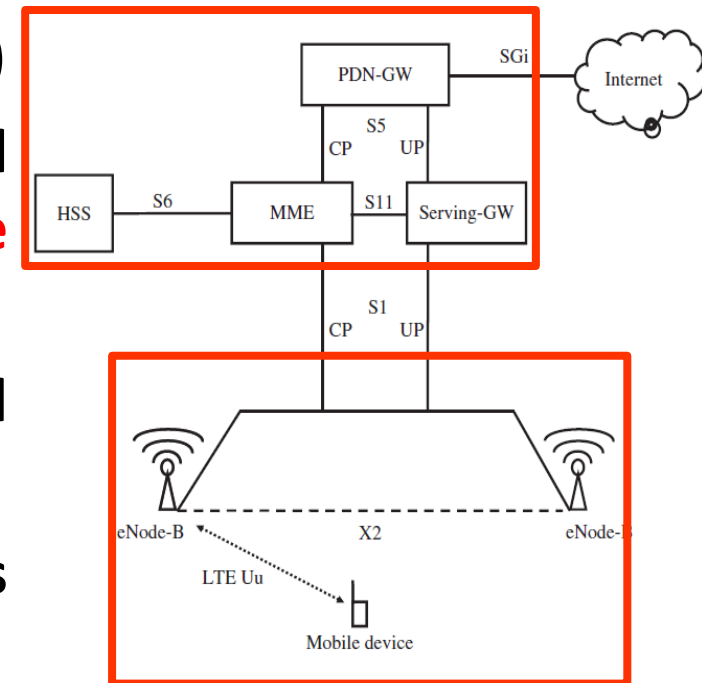

# LTE Network Architecture

## LTE Mobile Devices

70

- **Most LTE-capable devices** also **support other radio technologies** such as **GSM** and **UMTS**.
- As a consequence, **most LTE devices support not only one or more LTE frequency bands** but also **those for the other technologies**.
  - ▣ This is a **challenge for antenna and transmitter design** due to the **small size of devices** and **limited battery capacity**.

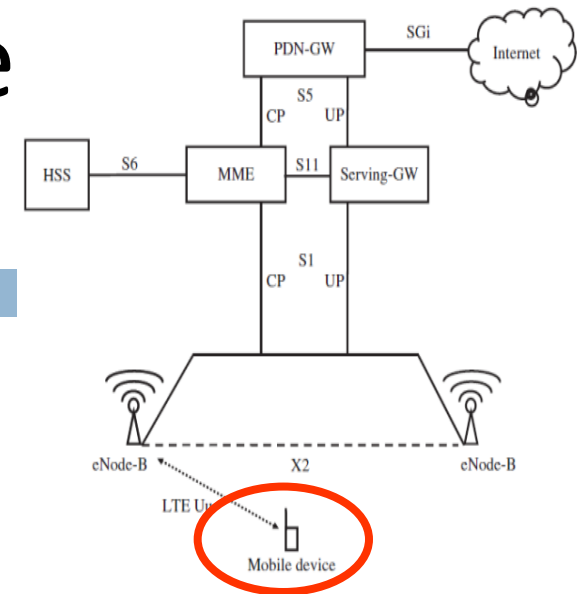

LTE Frequency Bands in Europe	Downlink (DL) (MHz)	Uplink (UL) (MHz)	UL/DL separation (duplex gap in MHz)	Duplex mode	Maximum carrier bandwidth (MHz)
Europe					
7	2620–2690	2500–2570	50	FDD	20
3	1805–1880	1710–1785	20	FDD	20
1	2110–2170	1920–1980	130	FDD	20
20	791–821	832–862	10	FDD	20

# LTE Network Architecture

## The eNode-B

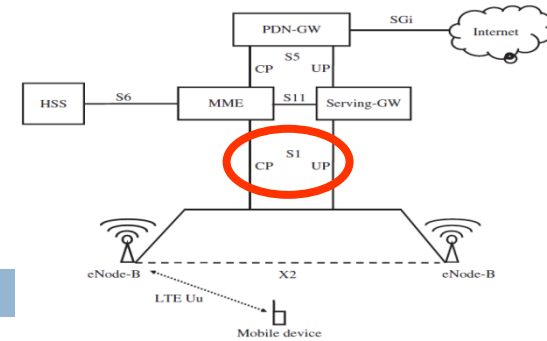

71

- The **S1-CP (S1 Control Plane)** part of the interface is mainly used for transferring **Control (signaling) messages** that concern the users of the system. E.g.,
  - ▣ For **authentication**, for **supplying keys for encrypting data** on the air interface and for the **establishment of the S1-UP** between the **eNode-B** and the **Core Network**.
  - ▣ Also once the **S1-UP is in place**, the **S1-CP** is used to **maintain the connection**, to **perform a handover** of the UE to another LTE, UMTS or GSM Base Station as required.
- The **S1-UP (S1 User Plane)** part of the interface is used for transferring the **user data**.



# LTE Network Architecture

## The Serving Gateway (S-GW)

72

- The **S-GW** is responsible for managing **User Data tunnels** between the **eNode-Bs** in the **Radio Network** and the **Packet Data Network Gateway PDN-GW** (which is the gateway router to the Internet),
  - I.e., it **Routes** and **forwards** user data packets.

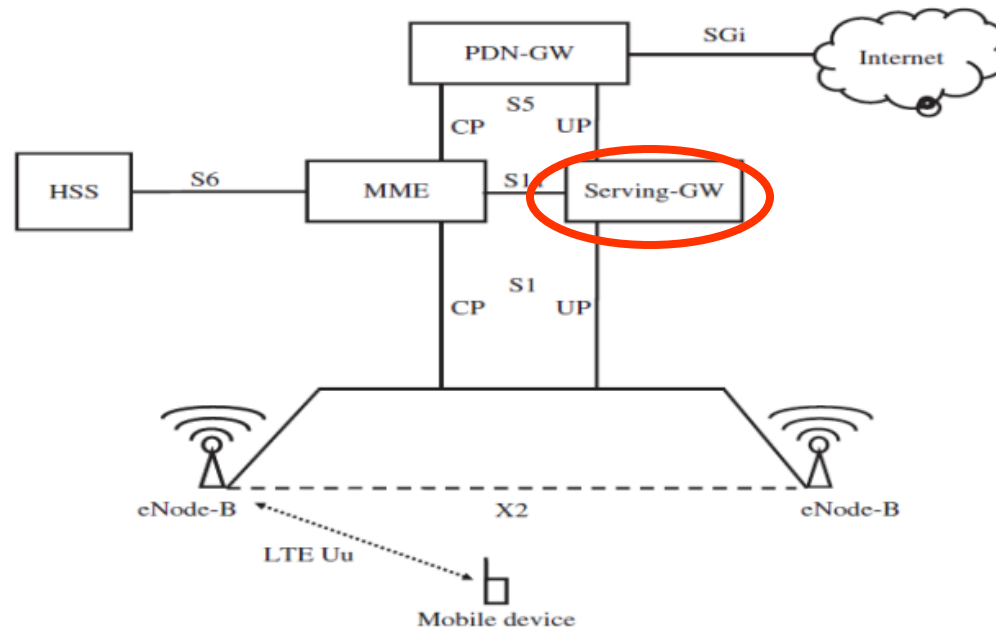

# LTE Network Architecture

## The Serving Gateway (S-GW)

73

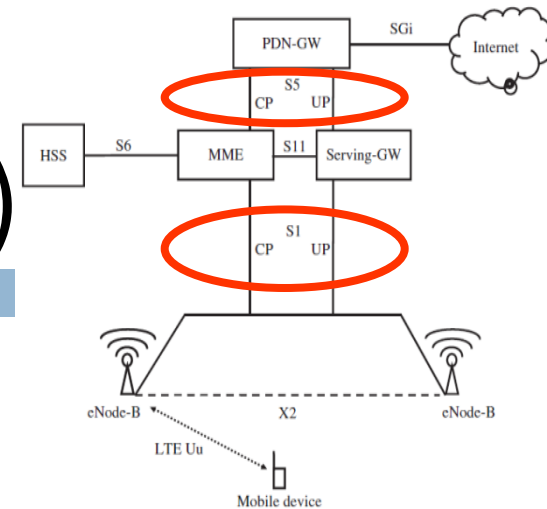

- Acts as the anchor for **Mobility** for the **User Plane** during an **inter- eNB** handovers (i.e., routes the User Data Traffic to the new eNB after a Handover).
  - ▣ **S1** and **S5 User Plane** tunnels for a single user are **independent of each other** and can be changed as required.
  - ▣ If, for example, a handover is performed to an eNode-B **under the control of the same MME/S-GW**, only the **S1 UP tunnel** needs to be modified **to redirect the user's data stream** to and from the new Base Station.
  - ▣ If the connection is handed over to an eNode-B that is **under the control of a new MME/S-GW**, the **S5 UP tunnel** (between the PDN-GW and the S-GW) **has to be modified as well**, so as the user's **data stream to be redirected** to the **new MME/S-GW**.

# LTE Network Architecture

## The Home Subscriber Server (HSS)

74

- LTE **shares its subscriber database** with GSM and UMTS (In these systems, the database is referred to as the **Home Location Register (HLR)**)
- In LTE, the name of the database has been **changed to HSS**
- In practice, the HLR and the HSS are **physically combined** to **enable seamless roaming** between the **different Radio Access Networks (RATs)**.
- **Each subscriber** has a record in the HLR/HSS and most properties are **applicable for communicating over all Radio Access Networks (2G, 3G, LTE, etc.)**.

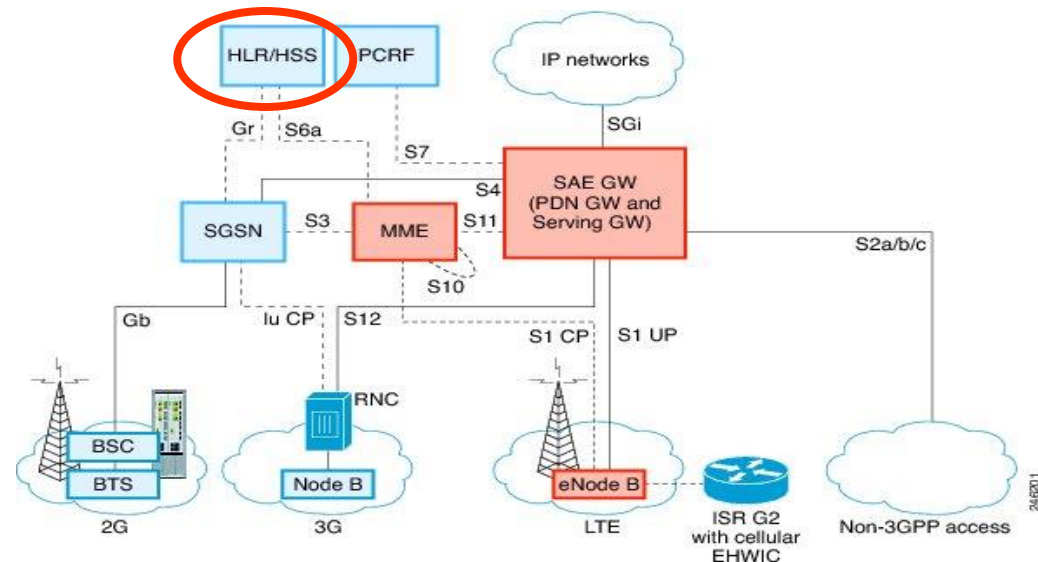

# LTE Network Architecture

## The Home Subscriber Server (HSS)

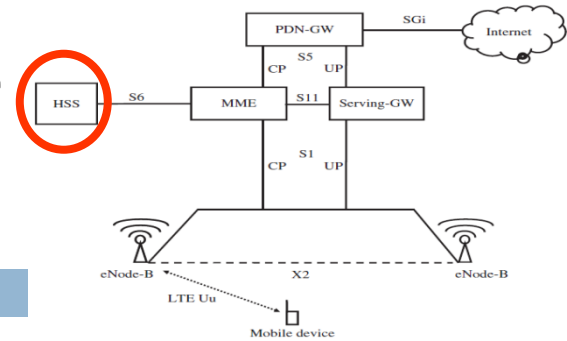

75

- The **most important user parameters** in the HSS are:
  - ▣ The user's **International Mobile Subscriber Identity (IMSI)**, which uniquely identifies a subscriber. The IMSI implicitly includes the **Mobile Country Code (MCC)** and **Mobile Network Code (MNC)** and is thus used when the user is roaming abroad to find the Home Network of the user to contact the HSS. A copy of the IMSI is stored on the SIM card of the subscriber;
  - ▣ **Authentication information** that is used to authenticate the subscriber and to generate encryption keys for the connection.
  - ▣ **Current Location** of the user (i.e., ID of current Serving Network if the user is roaming to a Foreign Network, ID of the Tracking Area (TA) if the user is roaming in his/her Home Network, etc.)

# LTE Network Architecture

## The Packet Data Network Gateway (PDN-GW)

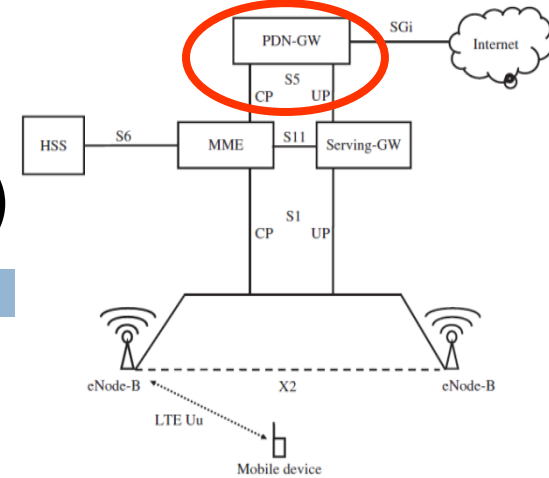

76

- **PDN-GW** provides **connectivity** between the **UE** and the **Internet** and other **external Packet Data Networks (PDNs)** by being the **point of Exit and Entry** for UE traffic.
- **PDN-GW** connects to the **S-GW** using the **S5 UP interface** and to the **MME** using the **S5 CP interface**.
- On the **S5 User Plane (UP)**, this means that
  - ▣ **Data packets destined for a user** are **encapsulated into an S5 User Plane (UP) tunnel** and **forwarded to the S-GW**, which is **currently responsible for this user**.
  - ▣ The **S-GW** then **forwards the data packets over the S1 interface** to the **eNode-B** that **currently serves the user**,
  - ▣ Finally, the **eNode-B sends the data packets over the air interface** to the **user's Mobile Device**.

# LTE Network Architecture

## The Packet Data Network Gateway (PDN-GW)

77

- The **PDN-GW** is also responsible for **assigning IP addresses to Mobile Devices**.
- When the **MME authenticates the subscriber** it **requests an IP address from the PDN-GW for the Mobile Device** (This is done through the **S5 Control Plane (CP) interface**)

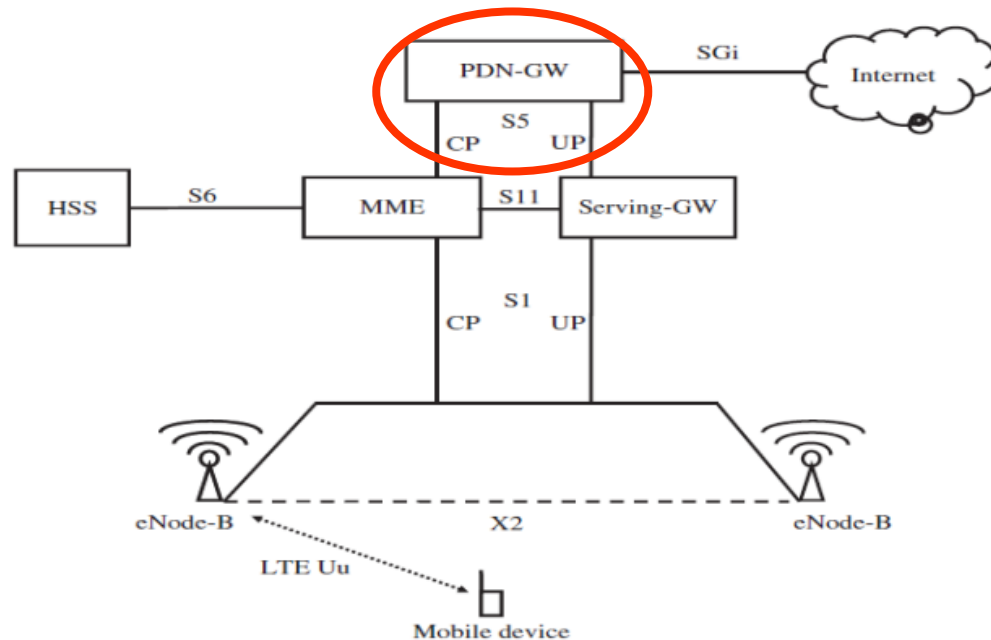

# LTE Network Architecture

## The Packet Data Network Gateway (PDN-GW)

78

- The **PDN-GW** acts as the **anchor for mobility** between **3GPP** (i.e., legacy systems as **GSM, GRPS, UMTS**) and **Non-3GPP access** technologies such as **WiMAX** (i.e., **PDN-GW** facilitates handovers between different Radio Access Technologies (RATs))

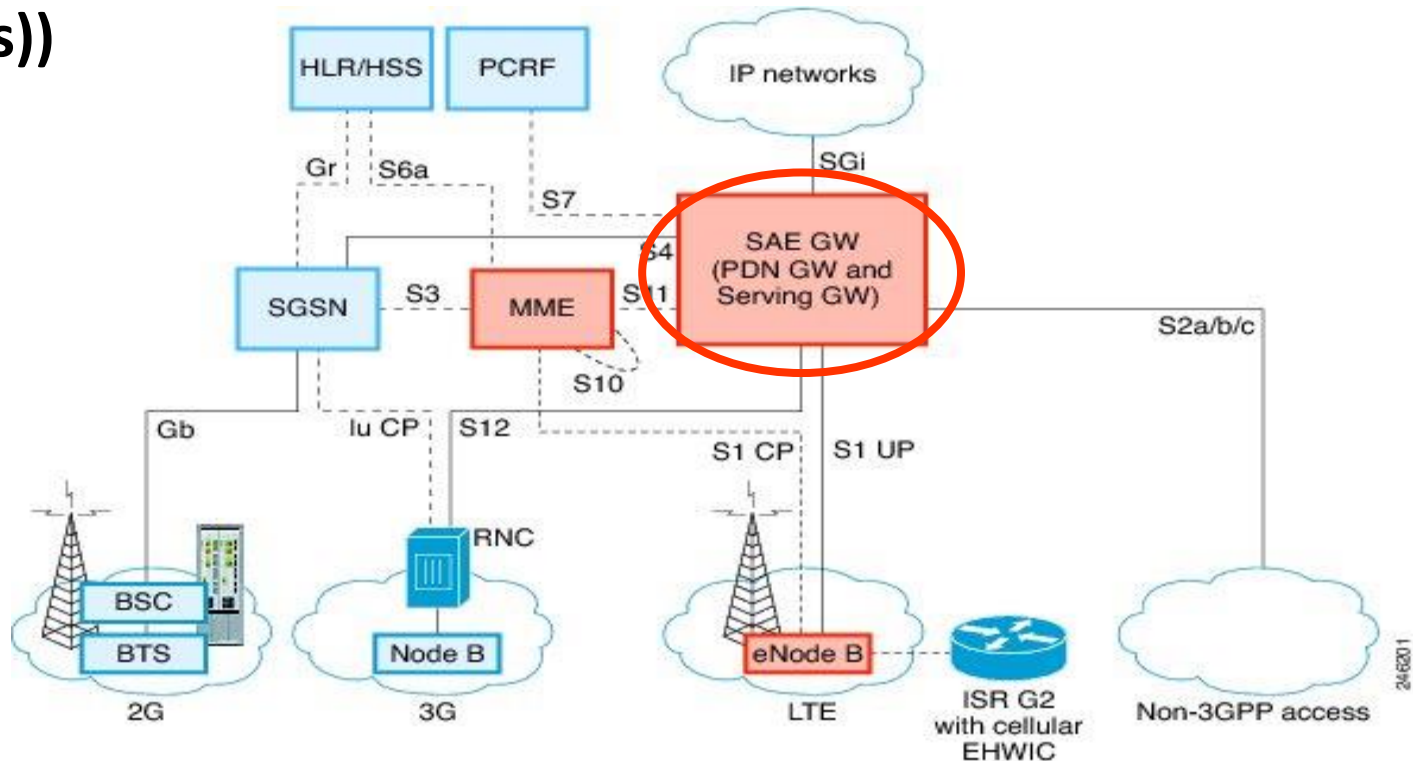

# LTE Network Architecture

## The Packet Data Network Gateway (PDN-GW)

79

- The PDN-GW plays an **important part** in **International Roaming scenarios**.
- For example, for a **user traveling abroad** and connected into a **Foreign Network**, the **MME/S-GW** in the **Foreign Visited network** will **contact** the **PDN-GW** in the **user's Home Network** to **query the HLR\HSS database** for **user authentication purposes**.

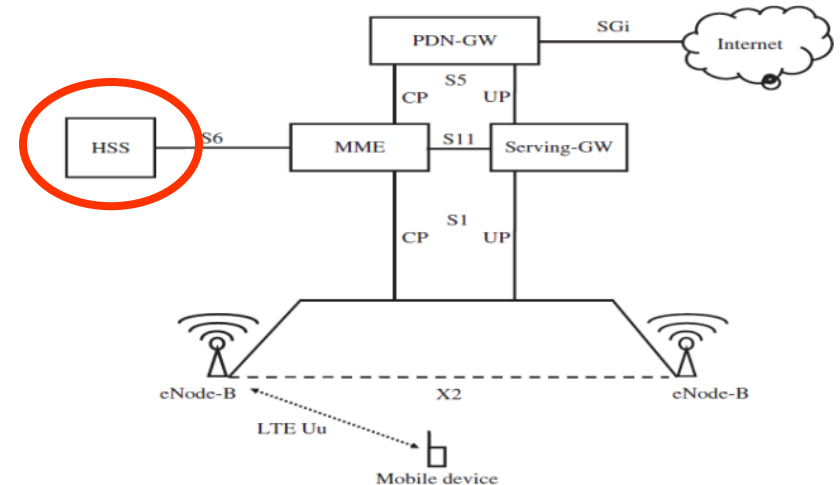



# LTE Requirements

- **Outlined in 3GPP TR 29.913 and described in seven different areas**
  - **Capabilities**
  - **System performance**
  - **Deployment related aspects**
  - **Architecture and migration**
  - **Radio Resource Management**
  - **Complexity**
  - **General aspects**

# LTE Requirements

81

## □ Capabilities

- DL data rate > 100 Mbps in 20 MHz
- UL data rate > 50 Mbps in 20MHz
- Rate scales linearly with spectrum
- Latency User plane: < 5ms
- Latency Control plane: < 50ms
- Support for 200 mobiles in 5MHz, 400 mobiles in more than 5MHz

# LTE Requirements

82

- **System Performance (Baseline is HSPA Rel. 6)**
  - Maximum performance for low mobility users (0-15km/h)
  - High performance up to 120 km/h
  - Maximum supported speed 500km/h
  - Cell range
    - 5 km - optimal size
    - 30km sizes with reasonable performance
    - up to 100 km cell sizes supported with acceptable performance

## Throughput requirements relative to baseline

Performance measure	DL target relative to base line	UL target relative to baseline
Average throughput per MHz	3-4 times	2-3 times
Cell edge user throughput per MHz	2-3 times	2-3 times
Spectrum efficiency (bit/sec/Hz)	3-4 times	2-3 times

# LTE Requirements

## Deployment Related Aspects

- LTE may be deployed as standalone or together with WCDMA/HSPA and/or GSM/GPRS
- Co-existence with legacy standards (users can transparently start a call or transfer of data in an area using an LTE standard, and, when there is no coverage, continue the operation without any action on their part using GSM/GPRS or W-CDMA-based UMTS)
- Handover interruption time targets specified

	Non-real time services (ms)	Real time services (ms)
LTE to WCDMA	500	300
LTE to GSM	500	300

# LTE Requirements

84

## □ Spectrum Flexibility

- Support both FDD and TDD duplex schemes
- Channel bandwidth from 1.4 - 20MHz
- IMT 2000 bands (co-existence with WCDMA and GSM)

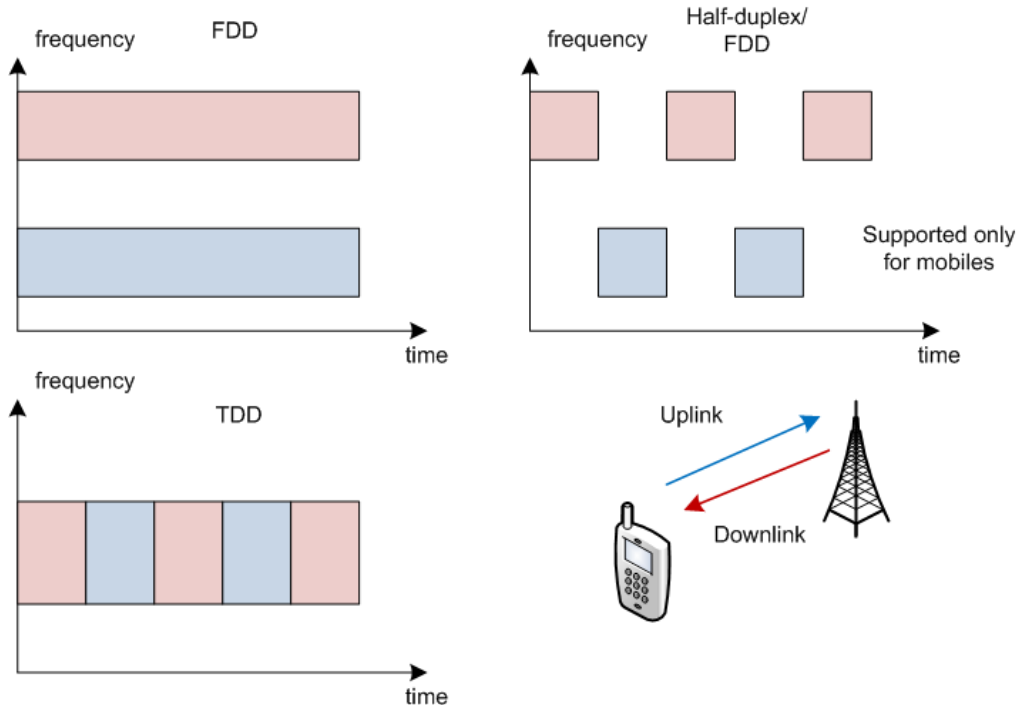

# LTE Requirements

85

- **Architecture and Migration**
  - **Single RAN architecture**
  - **RAN is fully packet based with support for real time conversational class**
  - **RAN architecture should minimize “single points” of failure**
  - **RAN should simplify and reduce number of interfaces**
  - **Radio Network Layer and Transport Network Layer interaction should not be precluded in interest of performance**
  - **QoS support should be provided for various types of traffic**

# LTE Requirements

86

- **Radio Resource Management**
  - Support for enhanced end to end QoS
  - Support for load sharing between different radio access technologies (RATs)
  
- **Complexity**
  - LTE should be less complex than WCDMA/HSPA

# LTE Channel Structure

## Radio Link Control (RLC) Layer

87

- Depending on the **Scheduler Decision**, a **certain amount of data** is **selected for transmission** from the RLC SDU (Service Data Units) buffer and the **SDUs** are **segmented/concatenated** to create the **RLC PDU (Protocol Data Unit)**. Thus, for **LTE** the **RLC PDU size varies dynamically**.
- Each **RLC PDU** includes a **header**, containing, among other things, a **sequence number** used for **in-sequence delivery** and also by the Retransmission mechanism **for retransmissions**
- Further, it is **responsible for monitoring packets' sequence numbers** and **detecting and retransmitting lost packets (ARQ)**.
- Although the **RLC is capable of handling transmission errors**, error-free delivery is in most cases **handled by the MAC-based Hybrid-ARQ** protocol.



# LTE Channel Structure

## Medium Access Control (MAC) Layer

88

- Data on a Transport channel is organized into Transport blocks.
- Each **Transmission Time Interval (TTI)**, at most one **Transport Block** of a certain size is transmitted over the radio interface to/from a Mobile Terminal (*in absence of **Spatial Multiplexing**; Applied with **MIMO transmissions***)
- Each Transport Block has an associated **Transport Format (TF)** which specifies **how the block is to be transmitted** over the radio interface (i.e., **Transport-Block size, Modulation Scheme, Antenna Mapping (e.g., type of MIMO used; 2x2, 4x2 etc.)**)
- By **varying the Transport Format**, the MAC layer can **realize different data rates**. **Rate Control** is therefore also known as **Transport-Format Selection**.
- In addition, the MAC layer is responsible for the **HARQ packet retransmission** functionality.

# Protocol Layer Overview

## Air interface protocol stack and main functions

89

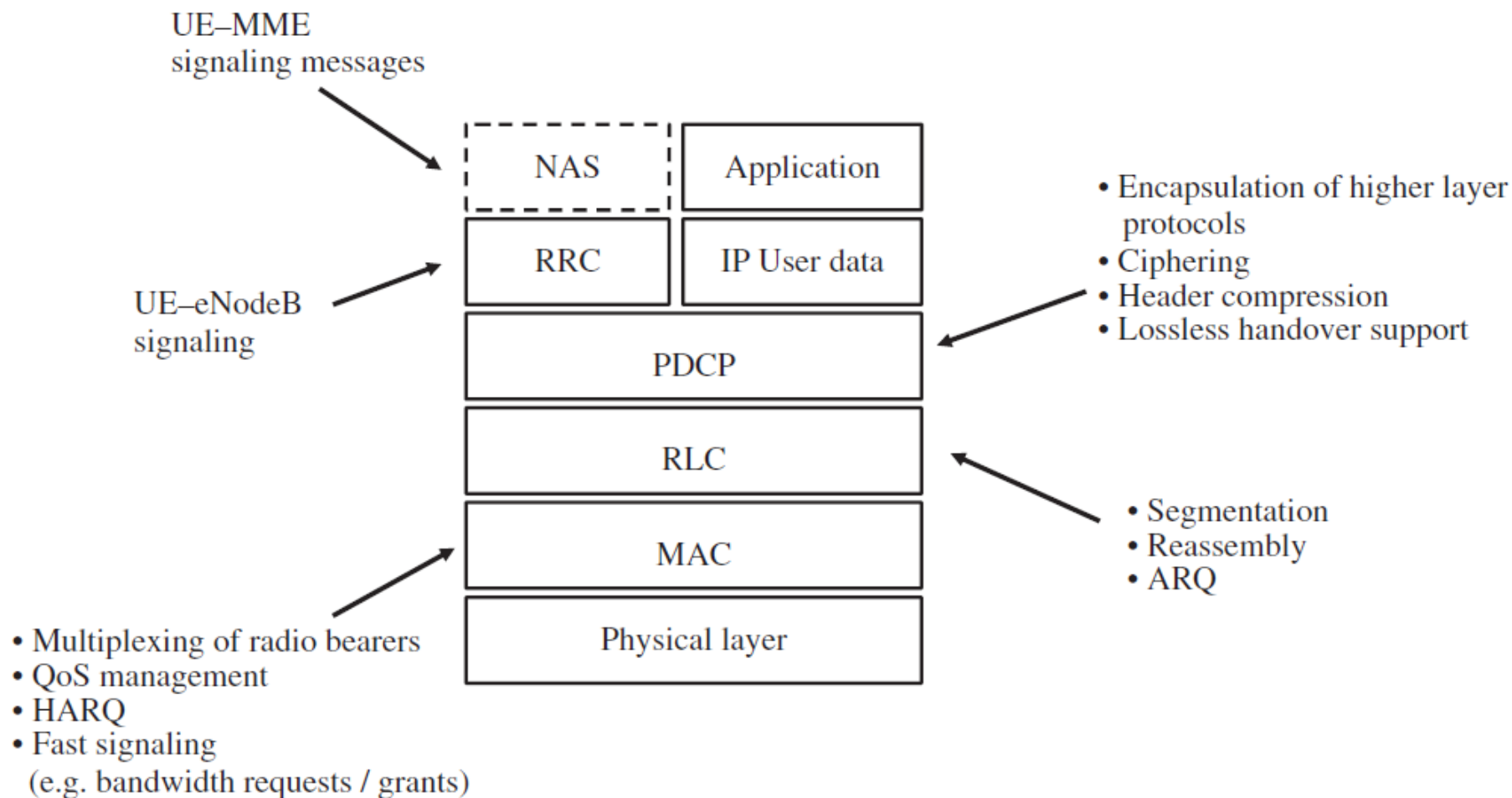

# Protocol Layer Overview

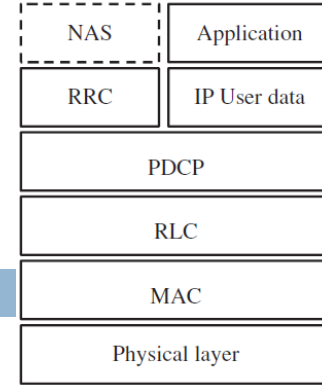

90

- **Control Protocols (NAS and RRC):**
  - **The top layer is the Nonaccess Stratum (NAS) protocol that is used for mobility management and other purposes between the Mobile Device and the MME.**
  - **NAS messages are tunneled through the radio network, and the eNode-B just forwards them transparently. NAS messages are always encapsulated in Radio Resource Control (RRC) messages over the air interface.**
  - **The other purpose of RRC messages is to manage the air interface connection and they are used, for example, for handover or bearer modification signaling.**
  - **As a consequence, an RRC message does not necessarily have to include a NAS message.**

# Protocol Layer Overview

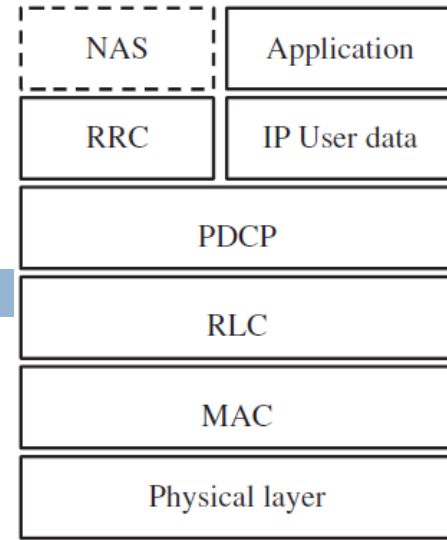

91

- **Use Data plane Protocols:**
  - ▣ Here, IP packets are always transporting user data and are sent only if an application wants to transfer data.
  - The first unifying protocol layer to transport IP, RRC and NAS signaling messages is the Packet Data Convergence Protocol (PDCP) layer.
    - ▣ PDCP is responsible for encapsulating IP packets and signaling messages, for ciphering, header compression and lossless handover support.

# Protocol Layer Overview

92

- **One layer below is the Radio Link Control (RLC).**
  - ▣ **It is responsible for segmentation and reassembly of higher layer packets to adapt them to a packet size that can be sent over the air interface.**
  - ▣ **Further, it is responsible for detecting and retransmitting lost packets (ARQ).**

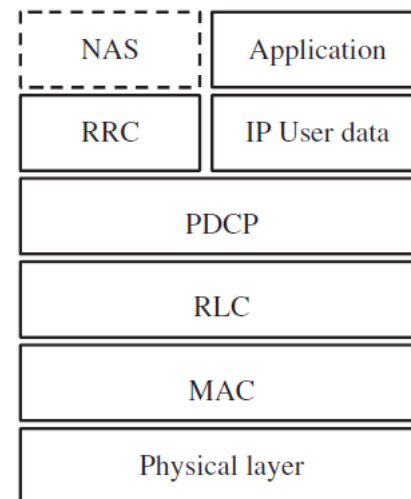

# Protocol Layer Overview

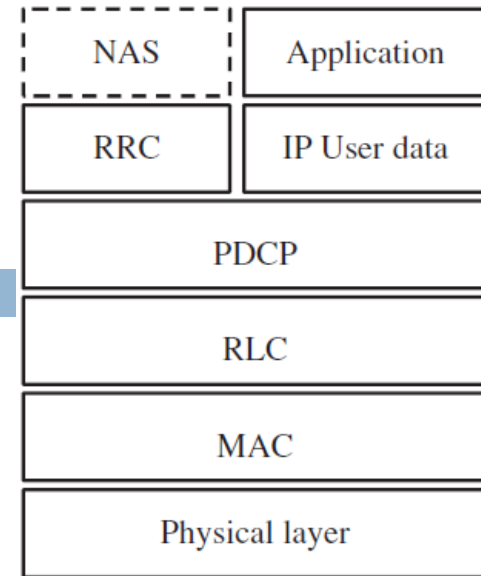

93

- **Just above the physical layer is the Medium Access Control (MAC)**
  - ▣ **It multiplexes data from different radio bearers and ensures QoS by instructing the RLC layer about the number and the size of packets to be provided.**
  - ▣ **In addition, the MAC layer is responsible for the HARQ packet retransmission functionality.**
  - ▣ **And finally, the MAC header provides fields for addressing individual mobile devices and for functionalities such as bandwidth requests and grants, power management**

# Air Interface in LTE

## SC-FDMA for Uplink Transmission

94

- The **number of subcarriers used** for distributing the user's data in the Uplink mainly **depends** on:
  - ▣ The user's Uplink **signal conditions** (measured at the eNodeB)
  - ▣ The **transmission power capabilities of the Mobile Device** and
  - ▣ The **number of simultaneous users in the uplink** (that will share the subcarriers).

# OFDMA

Vs

# SC-FDMA

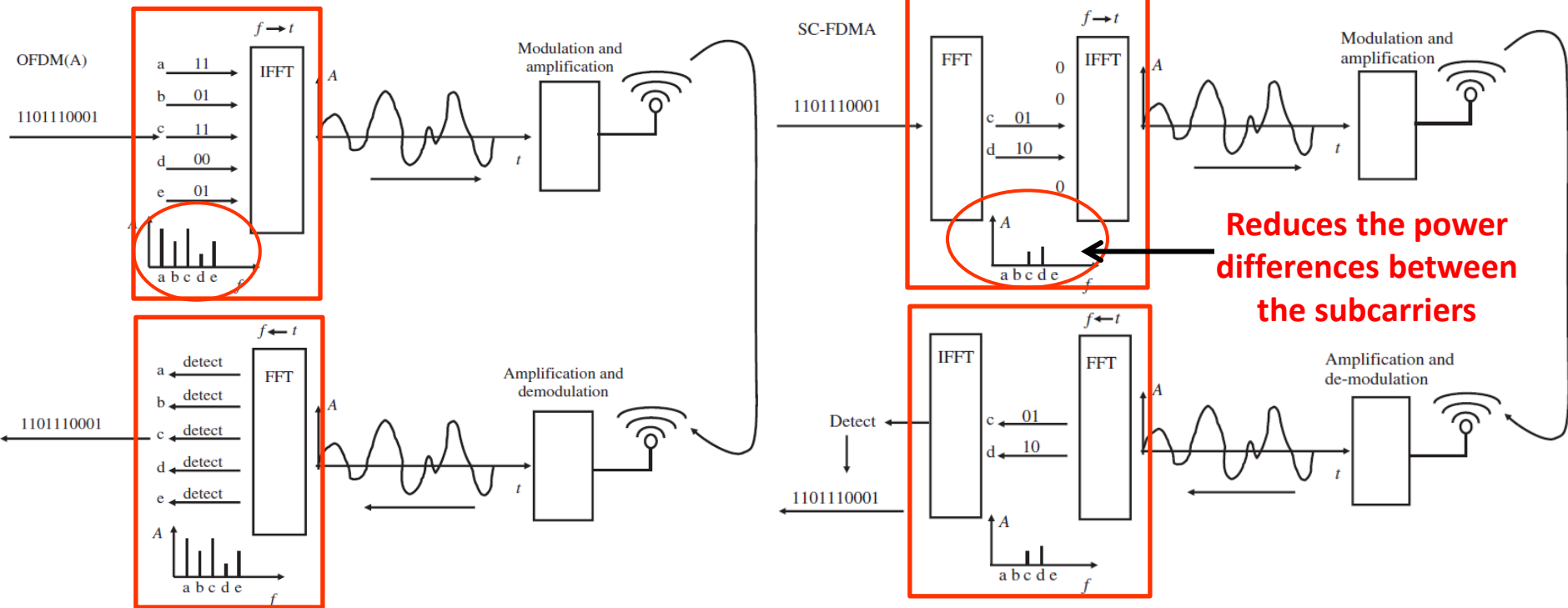

- With **SC-FDMA**, instead of dividing the data stream and putting the resulting substreams directly on the individual subcarriers (like OFDMA does), **the time-based signal is first converted to a frequency-based signal** with an **Fast Fourier Transform (FFT)** function.
- This **distributes the information of each bit onto all subcarriers** that will be used for the transmission and thus **reduces the power differences between the subcarriers** → **Reduces the Peak to Average Power Ratio (PAPR)**.
- This frequency vector is then fed to the IFFT as in OFDMA, which **converts the information back into a time-base signal** which is modulated, amplified and transmitted.



# LTE Channel Structure

## LTE Protocol Layer Overview

96

### **Control Plane Channels** (Channels that carries signaling (control) traffic)

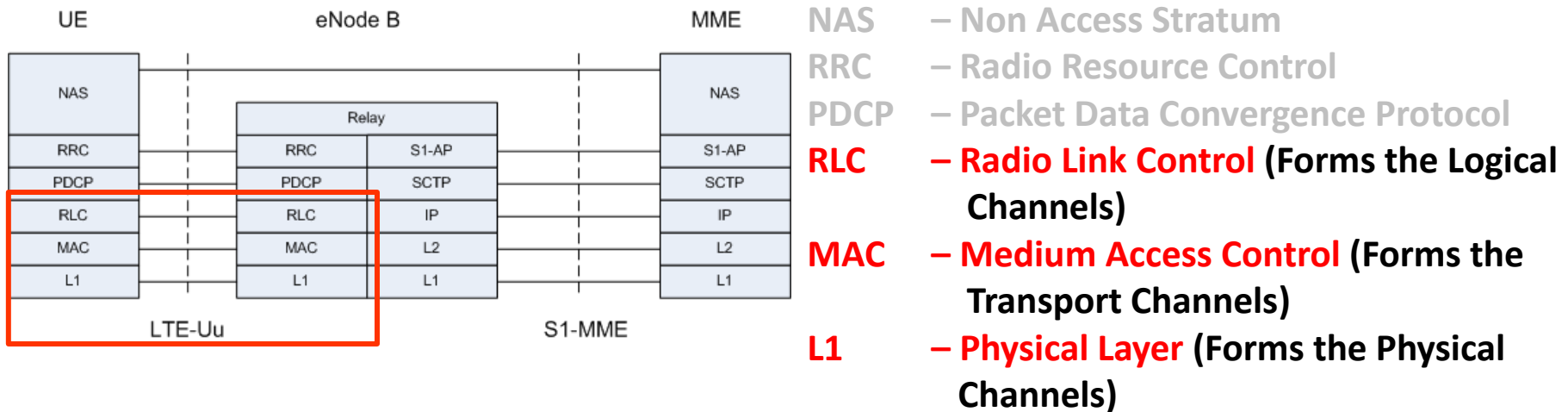

### **User Plane Channels** (Channels that carries user data traffic)

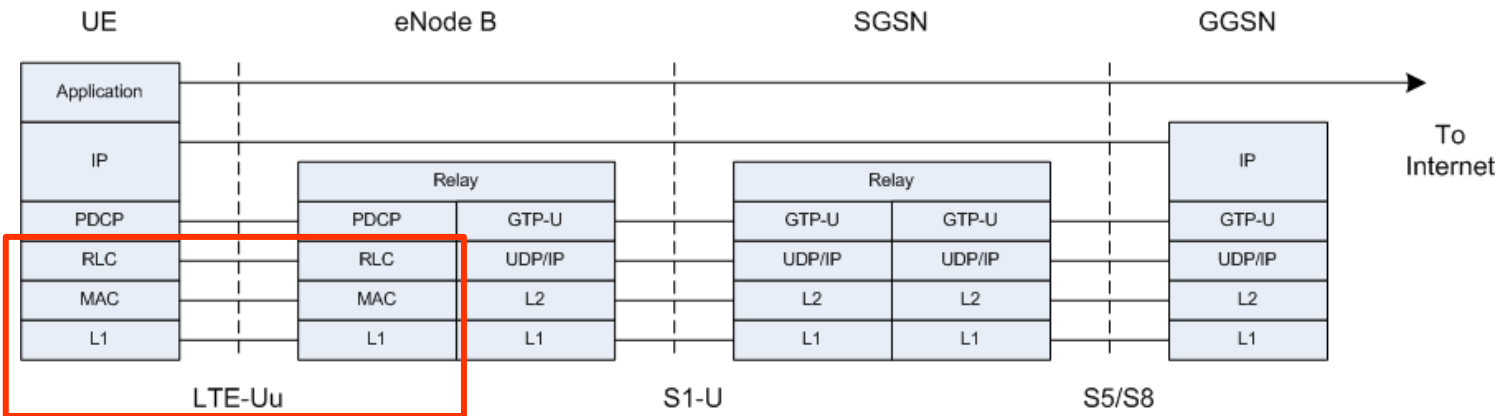

# LTE Channel Structure

## Type of Channels

97

*Note: LTE defines same type of channels as WCDMA/HSPA*

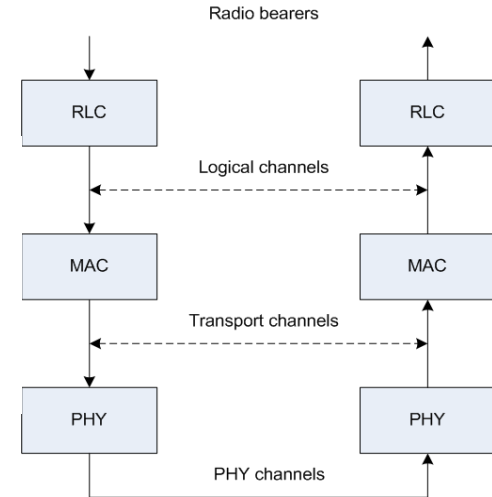

- **Logical channels**
  - **Formed by RLC** (Radio Link Control) layer
  - Characterized by the **type of information it carries (what)** (i.e., Control channel used to carry Control Information, a traffic channel is used for the user data)
- **Transport channels**
  - **Formed by MAC** (Medium Access Control) layer
  - Characterized by **how the data will be transmitted** (i.e., the defines the Transport Format (TF)\*) over the Radio Interface (i.e., the Physical Layer).
- **Physical channels**
  - **Formed by PHY** (Physical Layer – **OFDM Channels**)
  - Consist of a group of **RBs** that will **be assigned to the users** (the data in the RBs will be transmitted based of the TF selected by the MAC layer)

*\*Transport Format (TF): Specifies how the data is to be transmitted over the radio interface (i.e., e.g., Modulation Scheme, Antenna Mapping (e.g., type of MIMO used; 2x2, 4x2 etc.))*

# LTE Channel Mapping

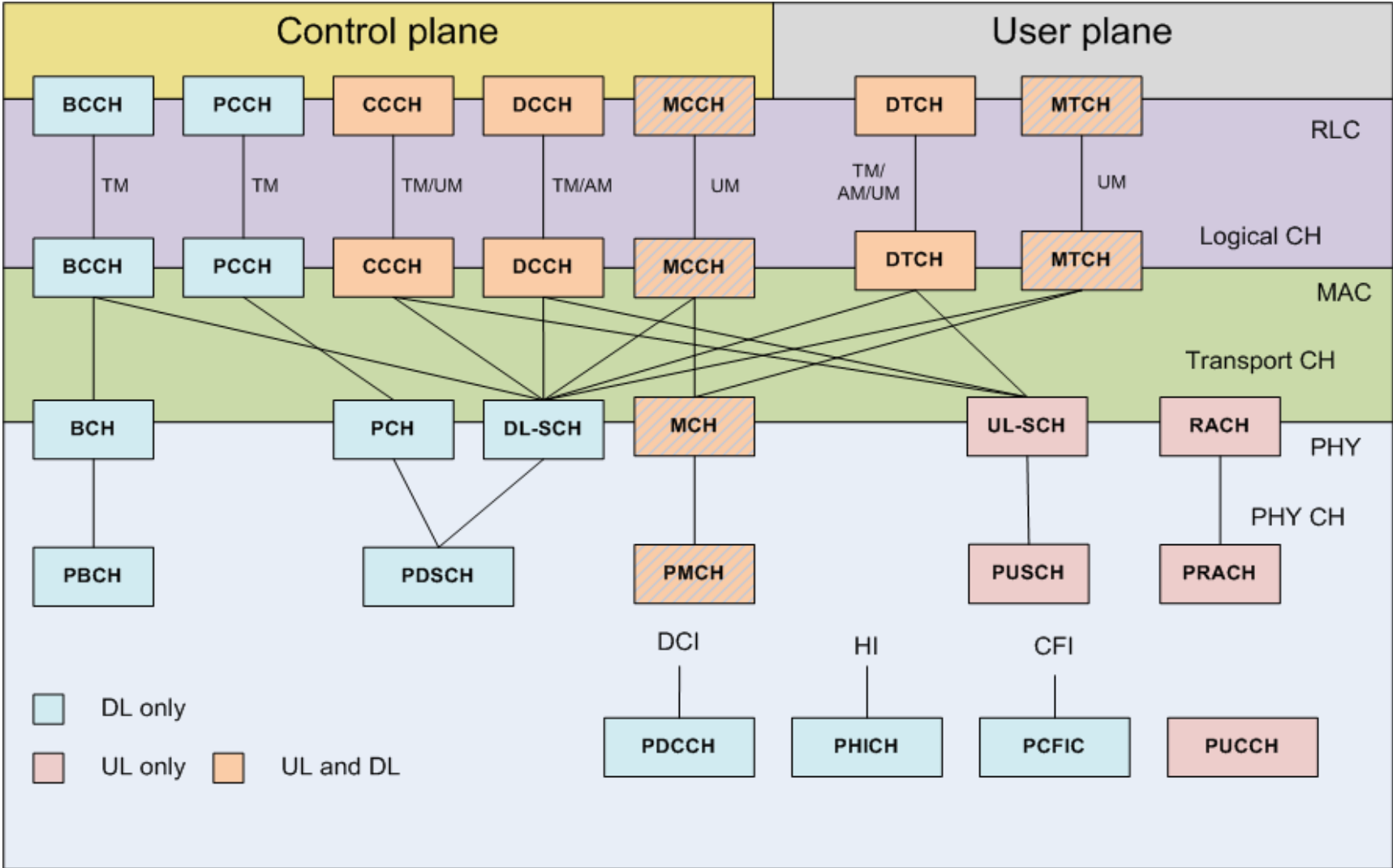

# LTE Logical Channels

99

- **BCCH** – Broadcast Control CH
  - ▣ System information sent to all UEs
- **PCCH** – Paging Control CH
  - ▣ Paging information when addressing UE
- **CCCH** – Common Control CH
  - ▣ Access information during call establishment
- **DCCH** – Dedicated Control CH
  - ▣ User specific signaling and control
- **DTCH** – Dedicated Traffic CH
  - ▣ User data
- **MCCH** – Multicast Control CH
  - ▣ Signaling for multi-cast
- **MTCH** – Multicast Traffic CH
  - ▣ Multicast data

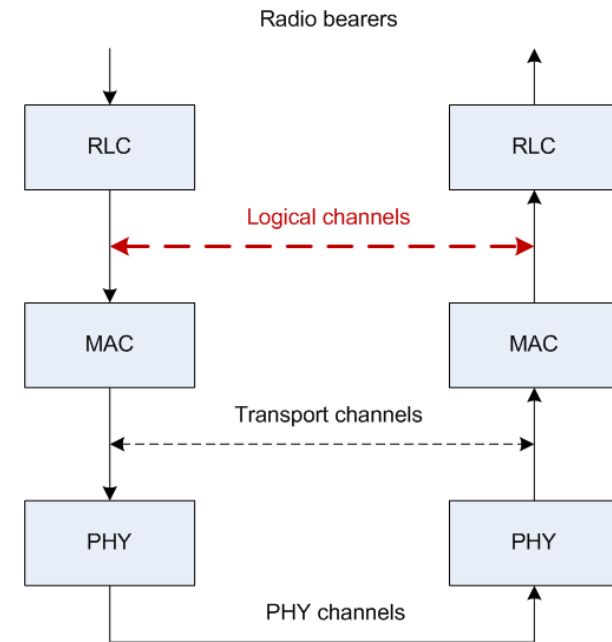

## LTE Channels

- Red** – Common,
- Green** – Shared,
- Blue** – Dedicated

# LTE Transport channels

100

- **BCH** – Broadcast CH
  - ▣ Transport for BCCH
- **PCH** – Paging CH
  - ▣ Transport for PCH
- **DL-SCH** – Downlink Shared CH
  - ▣ Transport of user data and signaling. Used by many logical channels
- **MCH** – Multicast channel
  - ▣ Used for multicast transmission
- **UL-SCH** – Uplink Shared CH
  - ▣ Transport for user data and signaling
- **RACH** – Random Access CH
  - ▣ Used for UE's accessing the network

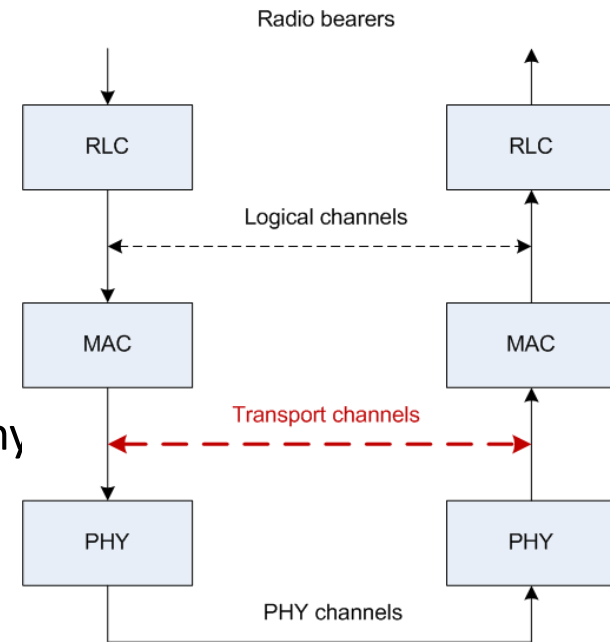

**Red** – Common,  
**Green** – Shared

# LTE Physical Channels

101

- **PDSCH** – Physical DL Shared CH
  - ▣ Uni-cast transmission and paging
- **PBCH** – Physical Broadcast CH
  - ▣ Broadcast information necessary for accessing the network
- **PMCH** – Physical Multicast Channel
  - ▣ Data and signaling for multicast
- **PDCCH** – Physical Downlink Control CH
  - ▣ Carries mainly scheduling information
- **PHICH** – Physical Hybrid ARQ Indicator
  - ▣ Reports status of Hybrid ARQ
- **PCFICH** – Physical Control Format Indicator
  - ▣ Information required by UE so that PDSCH can be demodulated (format of PDSCH)
- **PUSCH** – Physical Uplink Shared Channel
  - ▣ Uplink user data and signaling
- **PUCCH** – Physical Uplink Control Channel
  - ▣ Reports Hybrid ARQ acknowledgements
- **PRACH** – Physical Random Access Channel
  - ▣ Used for random access

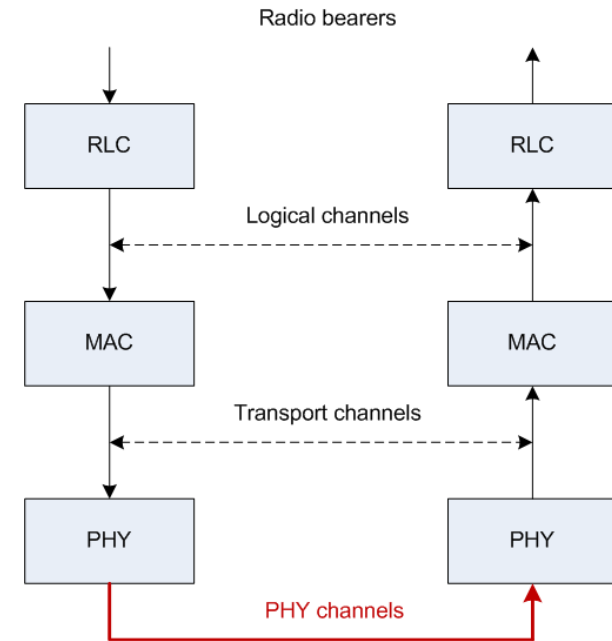

**Red** – Common,  
**Green** – Shared

# LTE Channel Model

## Downlink Direction

102

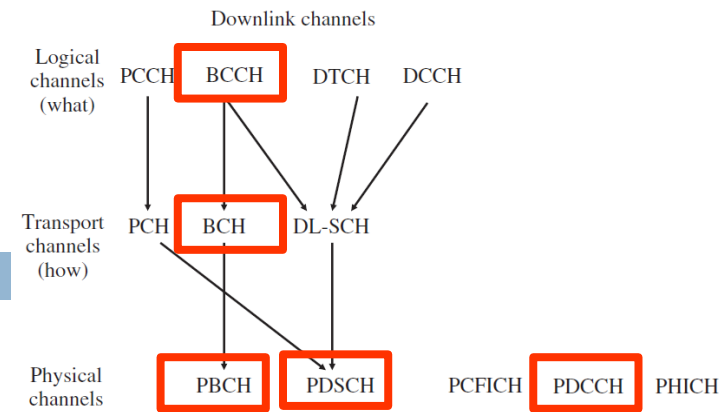

- LTE uses **System Information (SI)** messages to convey information that is required by all UEs that are currently in the cell.
- **Master Information Block (MIB)** is transported over the **Broadcast Channel (BCH)**.
- All other SI is **scheduled** in the **PDSCH** and their presence is **announced on the PDCCH** in a search space that has to be **observed by all UEs**.

System information blocks and content overview

Message	Content
MIB	Most essential parameters required for initial access
SIB 1	Cell identity and access-related parameters and scheduling information of system information messages containing the other SIBs
SIB 2	Common and shared channel configuration parameters
SIB 3	General parameters for intrafrequency cell reselection
SIB 4	Intrafrequency neighbor cell reselection information with information about individual cells
SIB 5	Interfrequency neighbor cell reselection parameters
SIB 6	UMTS inter-RAT cell reselection information to UMTS
SIB 7	GSM inter-RAT cell reselection information to GSM
SIB 8	CDMA2000 inter-RAT cell reselection information
SIB 9	If the cell is a femto cell, i.e. a small home eNode-B, this SIB announces its name
SIB 10	Earthquake and tsunami warning system (ETWS) information
SIB 11	Secondary ETWS information
SIB 12	Commercial mobile alert system (CMAS) information

# LTE Channel Model

## Uplink Direction

103

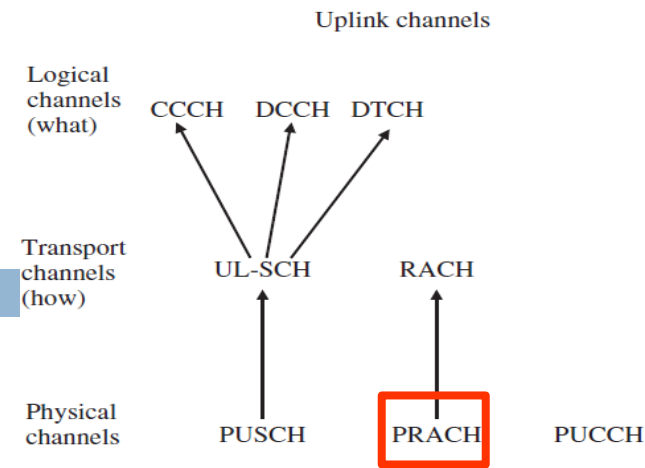

- Before a Mobile Device can send data in the uplink direction, it needs to **synchronize with the network** and has to **request the assignment of resources** (i.e., Resource Blocks) on the **PUSCH**.
- **Synchronizing and requesting initial uplink resources** is performed with a **Random Access Procedure** on the **Physical Random Access Channel (PRACH)**.
  - In these cases, a **contention-based procedure** is performed as it is possible that **several devices try to access the network with the same Random Access Channel (RACH) parameters at the same time.**

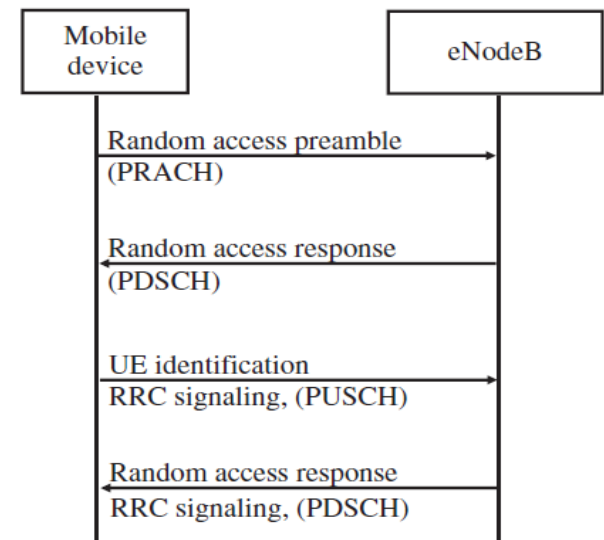



# MIMO Transmission & Adaptive Modulation and Coding

104

- In 3GPP Release 8, the **use of two or four simultaneous streams** is specified → In practice, **up to two data streams** are used today.
- In 3GPP Release 10 (LTE Advanced) the use of up to eight simultaneous data streams is specified; 8 x 8 MIMO)
- In theory, **the use of two independent transmission paths can double the achievable throughput** and four independent transmission paths can quadruple the throughput.
- **In practice, however, throughput gains will be lower** because of the **signals interfering with each other.**

**Single User – MIMO (SU-MIMO):**  
“Conventional” MIMO.  
One user gets the full benefit of the increased throughput.

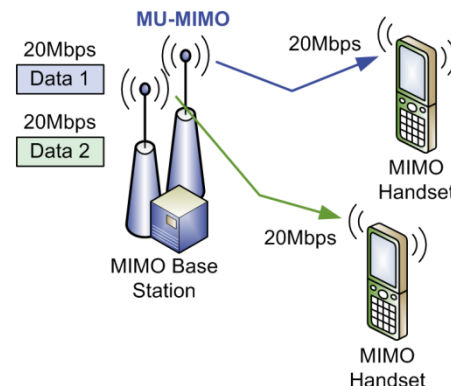
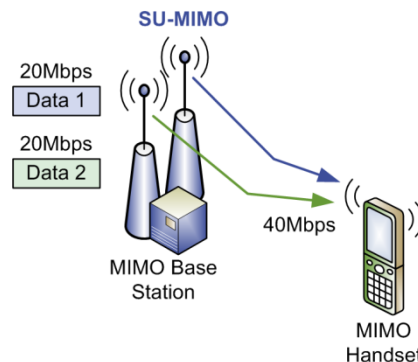

**Multi User – MIMO (MU-MIMO):**  
The BS schedules two users to be served at the same time.

# MIMO Transmission & Adaptive Modulation and Coding

105

## Multi-antenna types

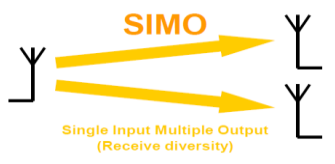
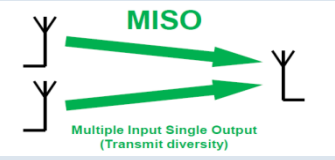
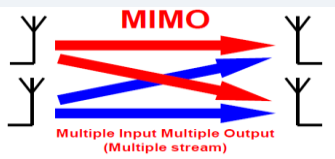
	Transmit Antennas	The Radio Channel	Receive Antennas
<b>SISO</b>	Single-input-single-output means that the transmitter and receiver of the radio system have only one antenna.		
<b>SIMO</b>	Single-input-multiple-output means that the receiver has multiple antennas while the transmitter has one antenna. <b>(Receive Diversity)</b>		
<b>MISO</b>	Multiple-input-single-output means that the transmitter has multiple antennas while the receiver has one antenna. <b>(Transmit Diversity)</b>		
<b>MIMO</b>	Multiple-input-multiple-output means that both the transmitter and receiver have multiple antennas. <b>(Spatial Multiplexing)</b>		

# MIMO Transmission & Adaptive Modulation and Coding

106

- Transmitting **simultaneous data streams over the same channel** is possible only if the **streams remain largely independent of each other** on the way from the Transmitter to the Receiver. This can be achieved if two basic requirements are met.
- **First Requirement for MIMO Transmission:**
  - ▣ On the transmitter side, **two or four independent hardware transmit chains are required to create the simultaneous data streams.**
  - ▣ In addition, **each data stream requires its own antenna.** For two streams, two antennas are required.

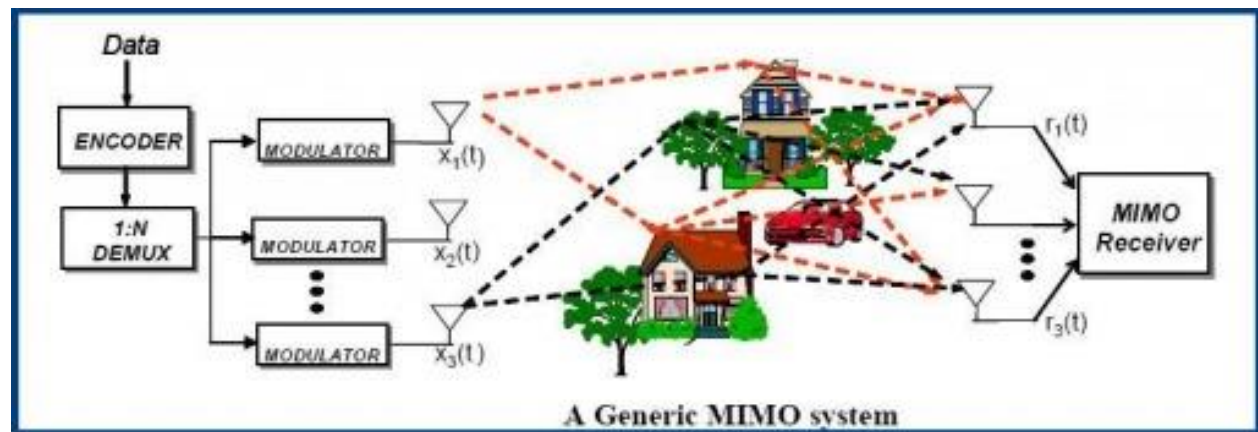

# MIMO Transmission & Adaptive Modulation and Coding

107

- **Second Requirement for MIMO Transmission:**
  - ▣ The signals have to **remain as independent as possible** on the **transmission path between the Transmitter and the Receiver.**
  - ▣ This can be achieved if the **simultaneous transmissions reach the Mobile Device via several independent paths**
  - ▣ However, the **simultaneous transmissions interfere with each other** to some degree, which reduces the achievable speeds.

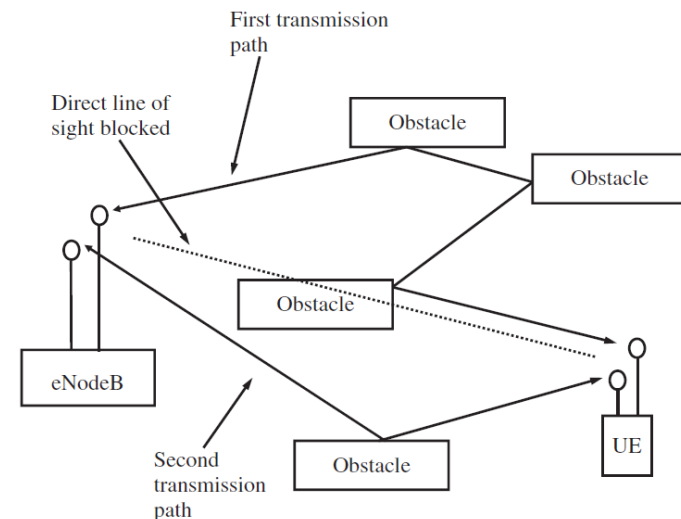

# MIMO Transmission & Adaptive Modulation and Coding

108

- Multiple antennas can also be used for **Transmit** and **Receive diversity** (e.g., MISO and SIMO transmission types)
- Here, the **same data stream** is transmitted (or received) **over several antennas**.
- This **does not increase the transmission speed** beyond what is possible with a single stream but it **helps the receiver to better decode the signal** and, as a result, **enhances data rates (throughput)** beyond what would be possible with a single transmit (or receive) antenna.

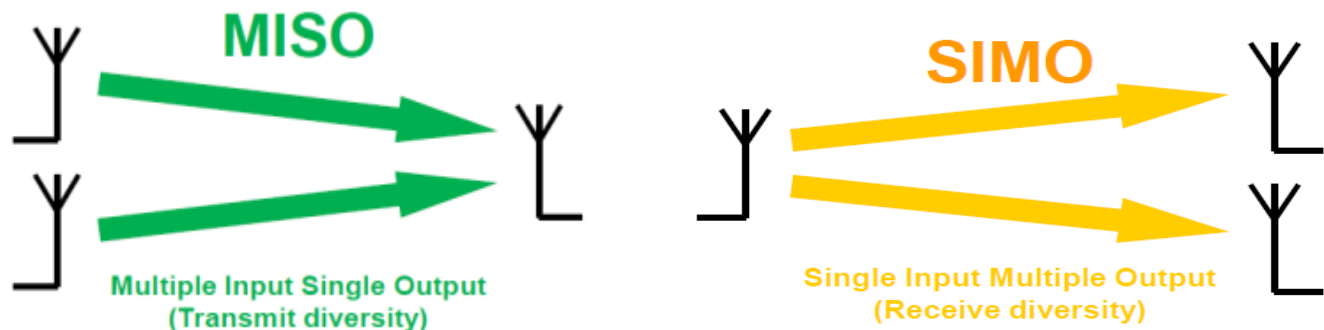

# Hybrid Automatic Repeat Request (HARQ)

- Despite **Adaptive Modulation and Coding** schemes, it is always possible that some of the transmitted data packets **are not received correctly**.
- ▣ In fact, it is even **desired that not all packets are received correctly** as this would indicate that the **modulation and coding scheme is too conservative** and hence **capacity on the air interface is wasted**.
- ▣ In practice, the **air interface is utilized best** if about **10% of the packets** have to be retransmitted because they have **not been received correctly**.

# Hybrid Automatic Repeat Request (HARQ)

110

- The **challenge of this H-ARQ approach** is to **report transmission errors quickly** and to ensure that packets are retransmitted as quickly as possible to **minimize the resulting packet delay and jitter**.
- Further, **the Modulation and Coding scheme** used during the transmission **must be adapted quickly** to keep **the error rate within reasonable limits**.
- The **HARQ scheme** is used in the **Medium Access Control (MAC) layer** for fast reporting and retransmission and can achieve an **overall round-trip delay times of the complete LTE system** of less than 20 milliseconds (much better values than those achieved by HSDPA ~ 80 - 100 ms)

